

Wiley Electronics LLC

Washer, Electrical Equipment Bond

WEEB

Patent Pending

INSTALLATION INSTRUCTIONS

For IronRidge

Please read carefully before installing.

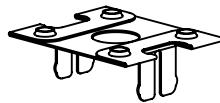

WEEB-DMC

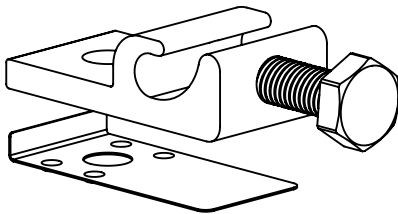

WEEBL-6.7 assembly

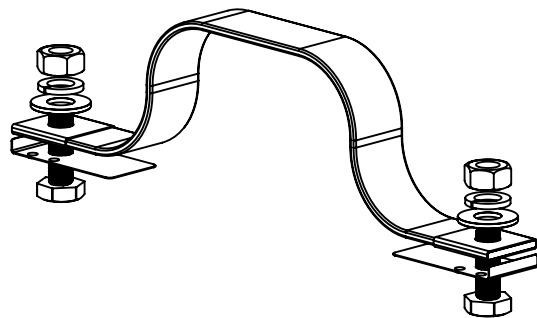

WEEB Bonding Jumper-6.7



Products are tested to UL 467 3098177
UL standard for safety grounding and bonding equipment

Document Number 104-0404-000039-000

WEEB COMPATIBILITY

The WEEB family of products can be used to bond anodized aluminum, galvanized steel, steel and other electrically conductive metal structures.

Standard Top Down Clamps

The WEEBs used for bonding the PV modules to the mounting rails are compatible with various cross-sections of module frames. The following are examples of module frames that are compatible. Notice that the WEEB teeth are positioned completely under the edge of the module frame.

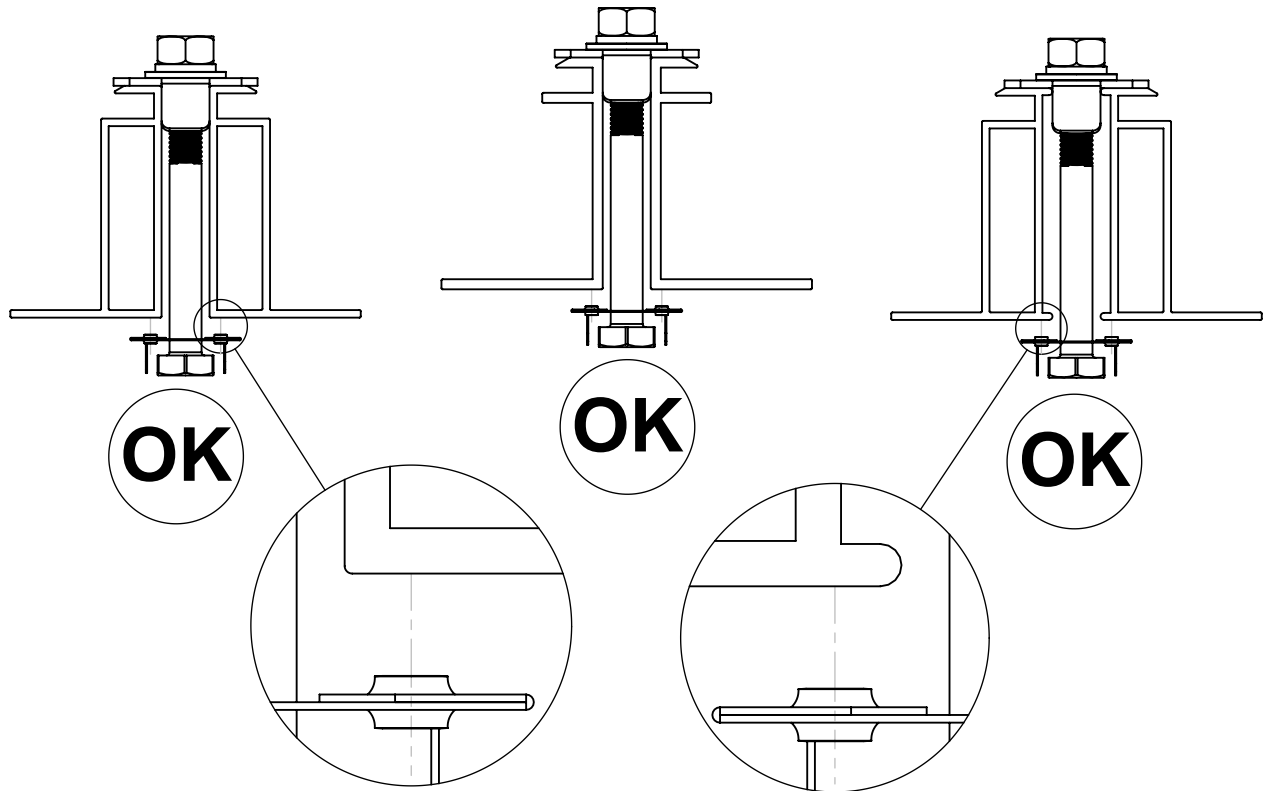

The following is an example of a module frame that is incompatible with the WEEB. The WEEB teeth are positioned only partially under the edge of the module due to the lip on the top edge of the module frame.

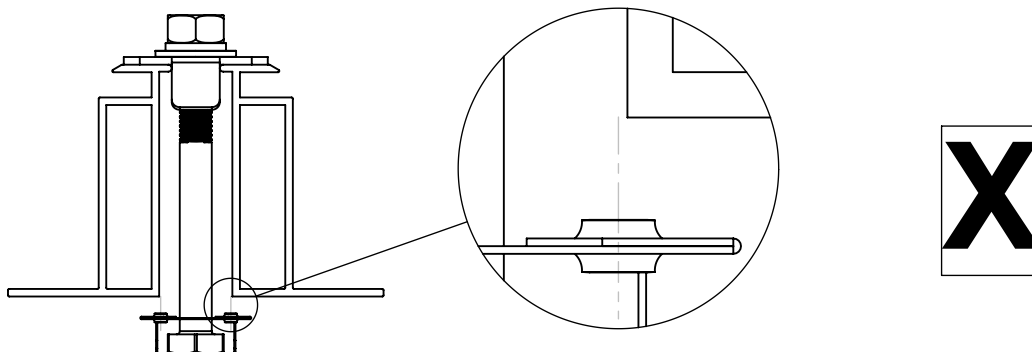

Top Down Clamps for Lipped Modules

The following are a few variations of lipped solar modules mounted with inverted U-shaped clamps. Notice that the force which the inverted U-shaped clamp exerts is in line with the WEEB teeth.

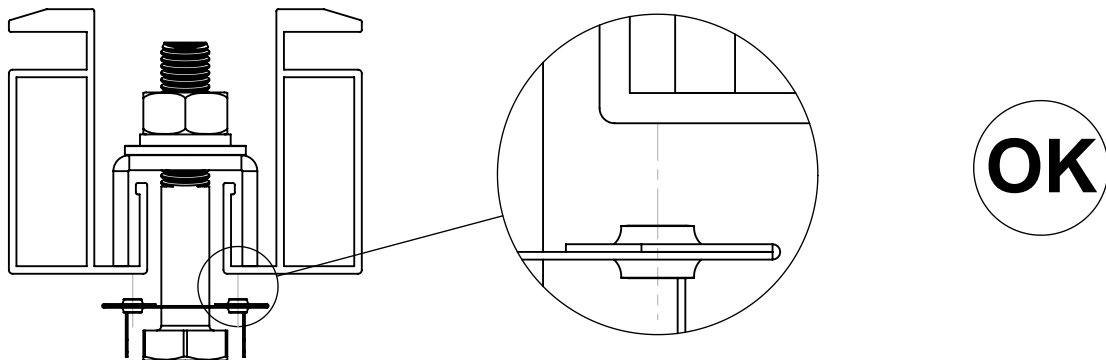

Low-Lipped Module

WEEB-DMC is not compatible with high lipped modules. The WEEB teeth do not intersect with the solar module frame.

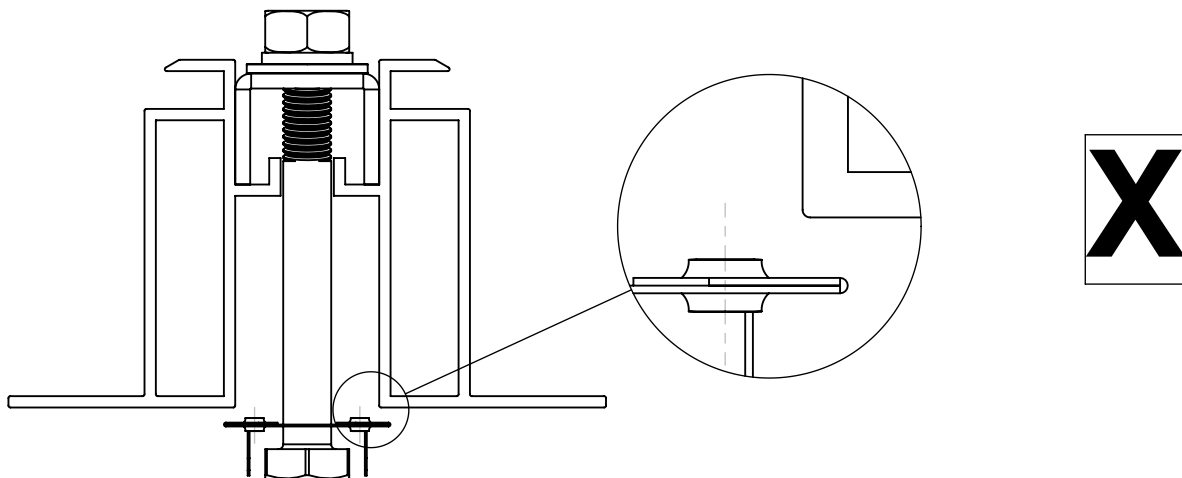

High-Lipped Module

SYSTEM OVERVIEW

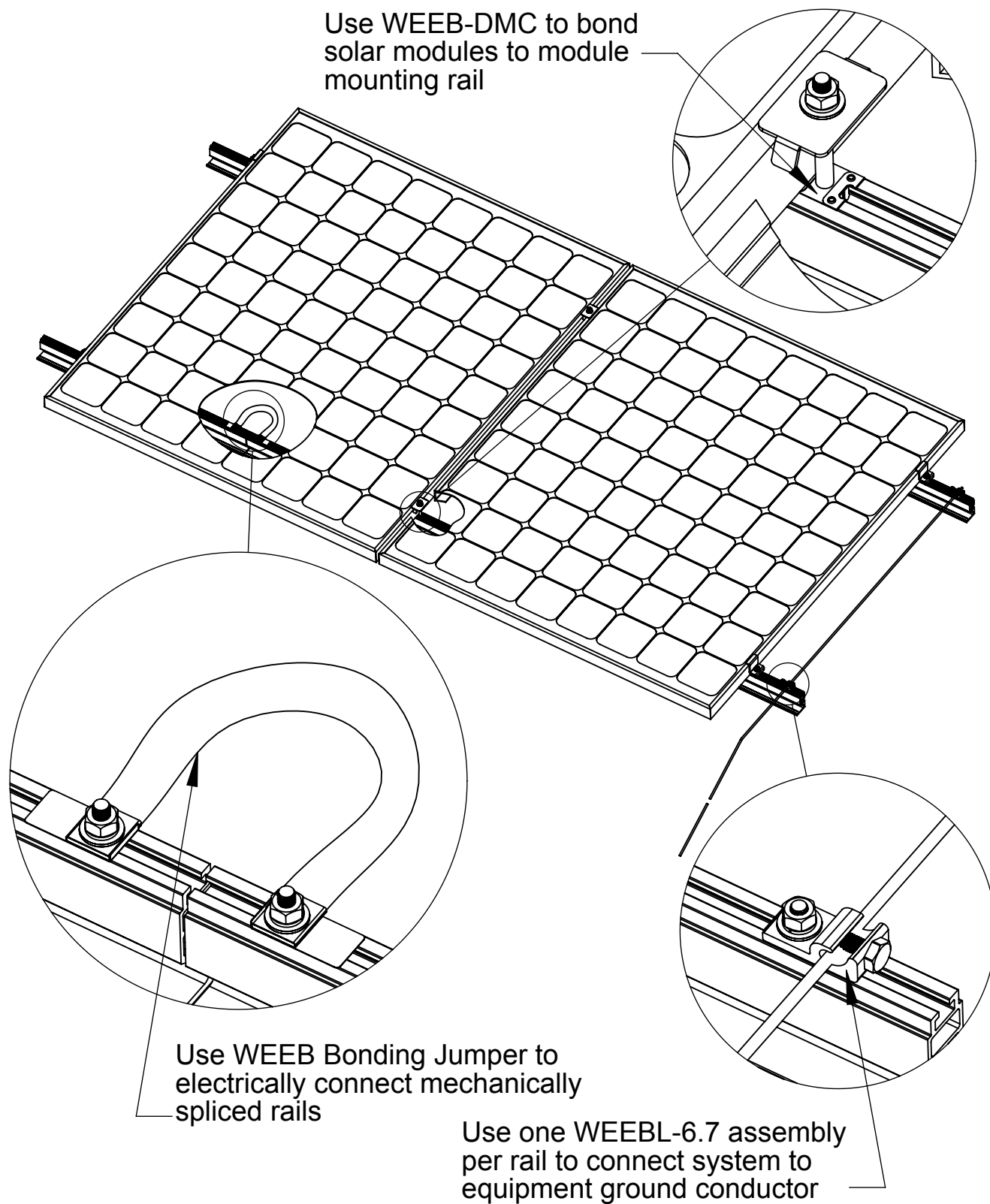

Important notes:

1. Use general purpose anti-seize compound on fastener threads when installing WEEBs.
2. WEEBs are intended for **SINGLE USE ONLY**. Functionality will not be guaranteed if reused.

WEEB-DMC ASSEMBLY

①

Inverted U-shaped mid-clamp

Mid-clamp

WEEB-DMC

WEEB-DMC

Pre-assemble WEEB-DMC to mid-clamp assembly as shown. Pre-assembling WEEB-DMC to mid-clamp assembly will contain the small individual parts, reducing the possibility of losing parts during installation.

②

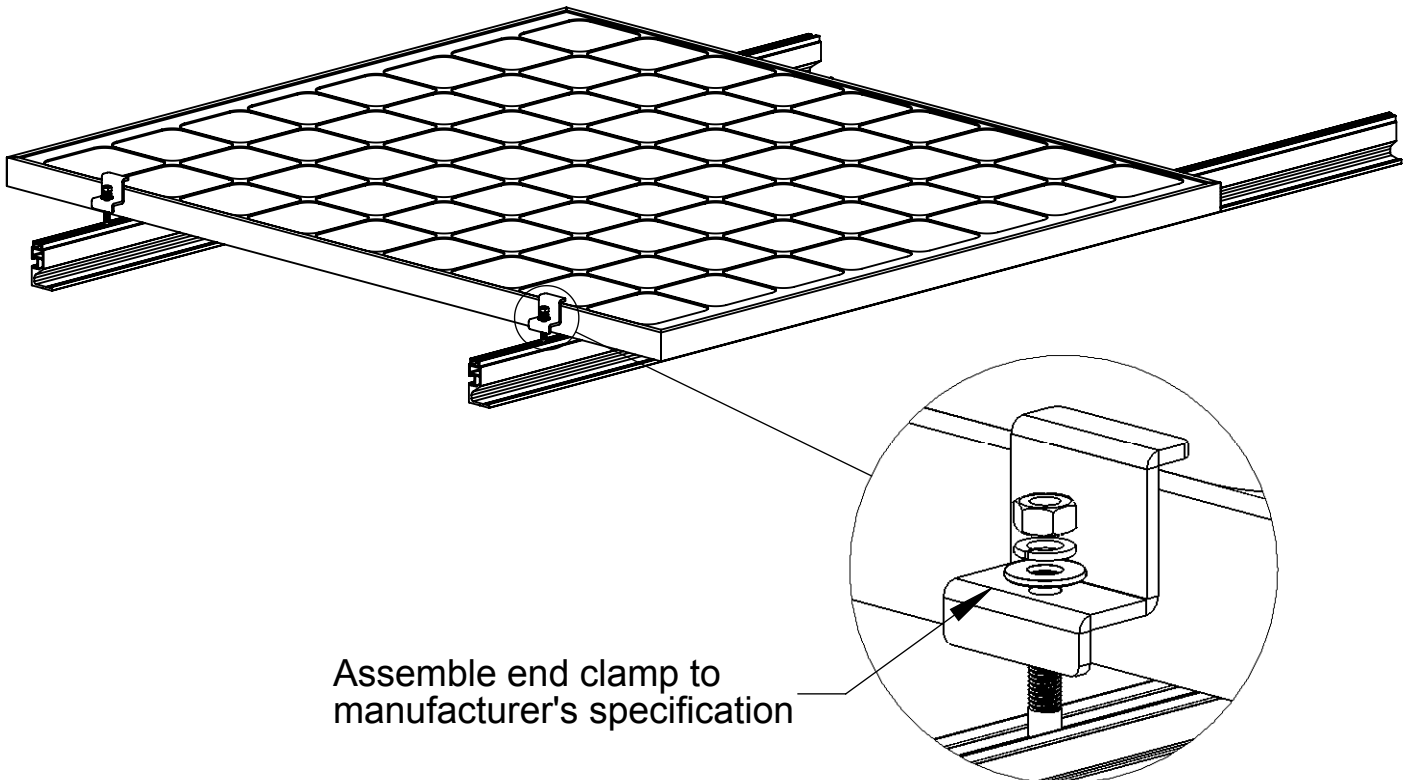

3

Slide pre-assembled
WEEB-DMC and mid-clamp
assembly into position

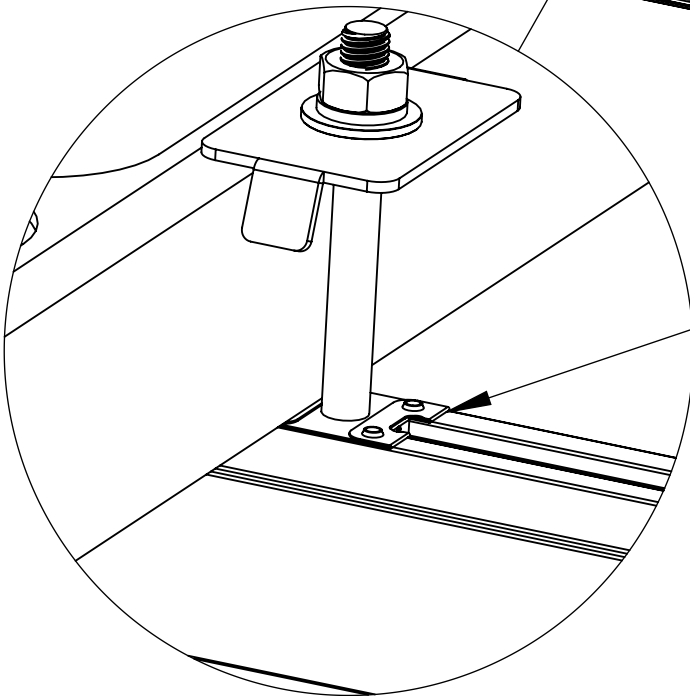
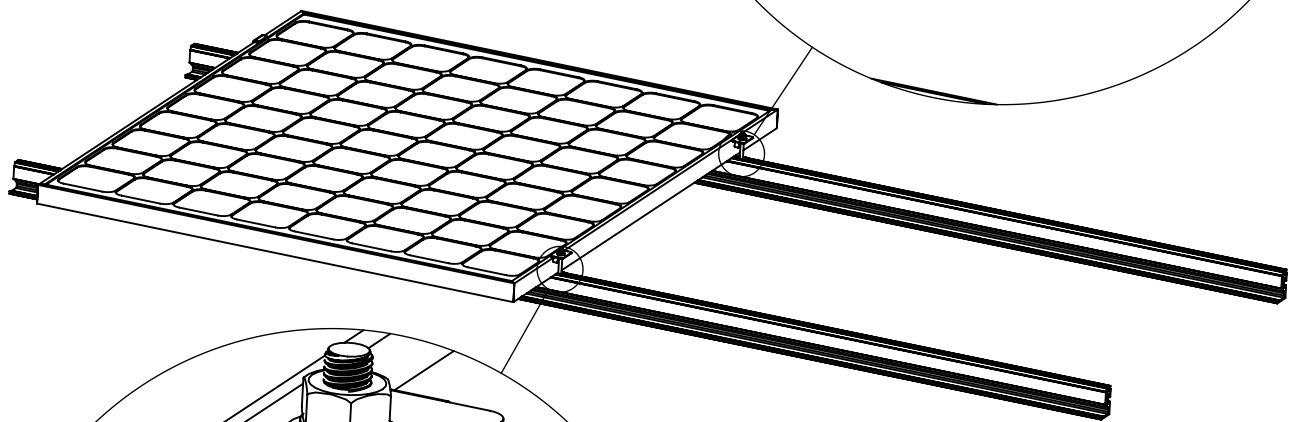
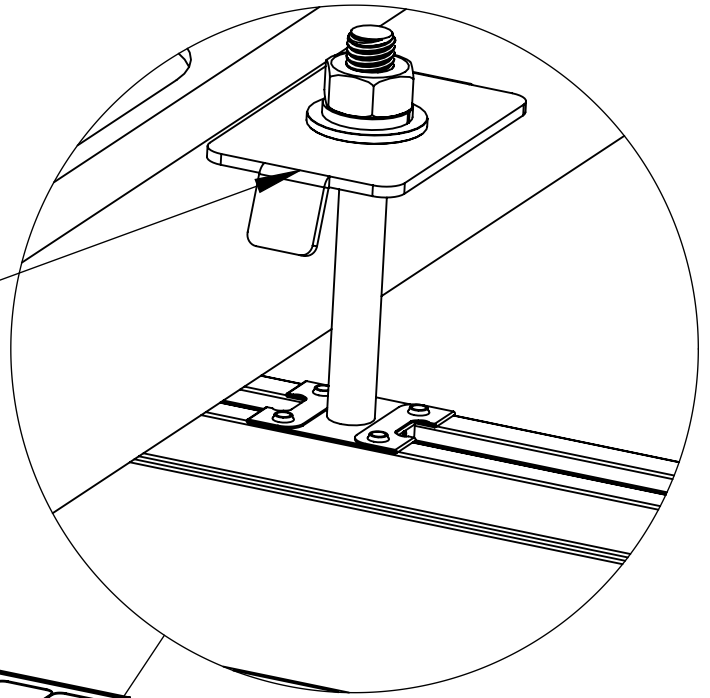

Slightly lift solar module and
slide WEEB-DMC and mid-
clamp assembly into position.
WEEB teeth will automatically
be aligned under the edge of the
module when mid-clamp
assembly is correctly installed.

Important note:

To correctly install mid-clamp assembly, ensure that the bolt is perpendicular to the mounting rail and both sides of the solar modules are completely positioned against the mid clamp. Refer to WEEB compatibility page for illustrations.

- ④ **Important note:**
WEEBs are for SINGLE USE ONLY! Do not torque fasteners down if position of solar modules is not finalized. Only slightly tighten fasteners to keep modules in place.

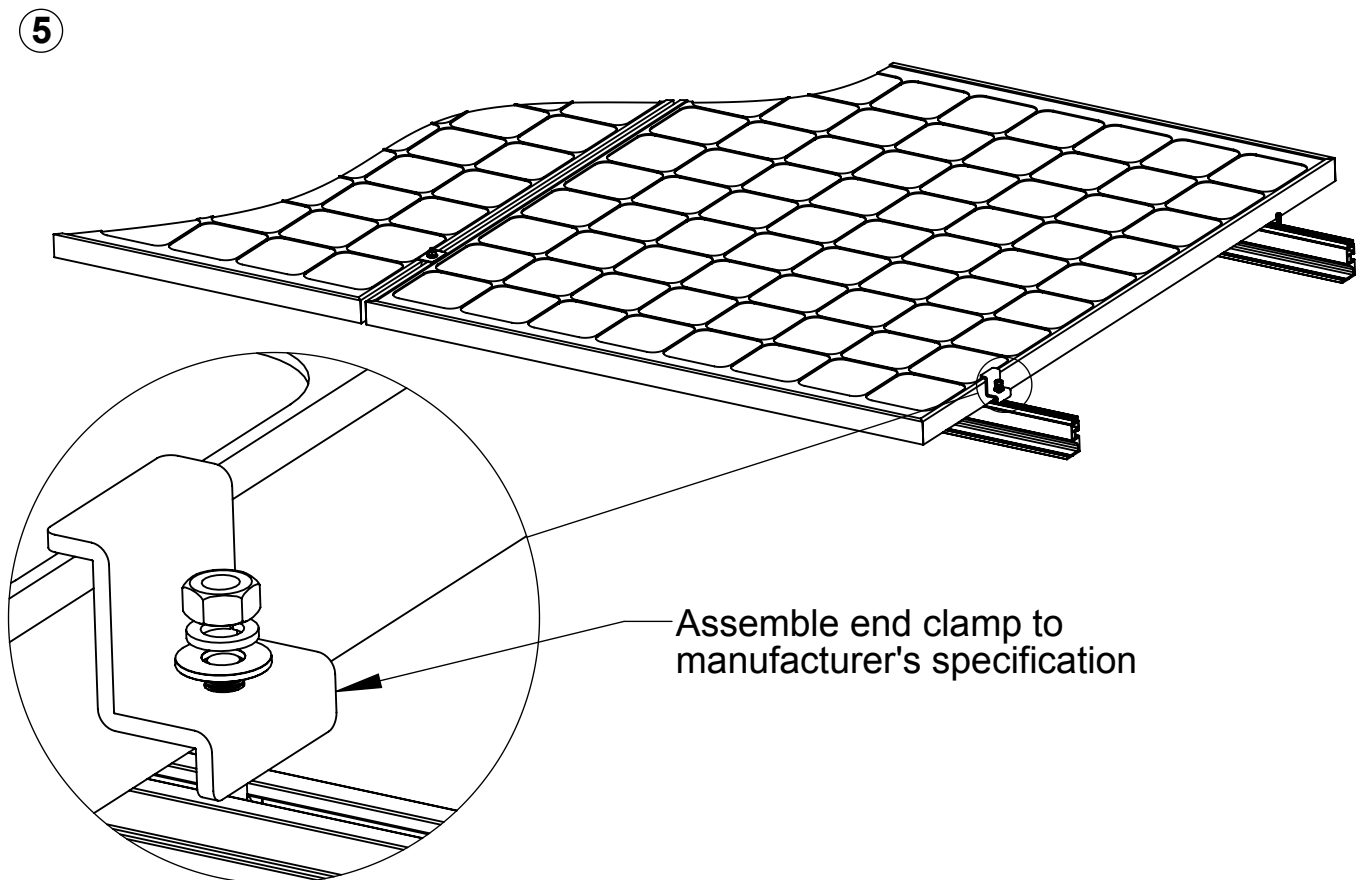
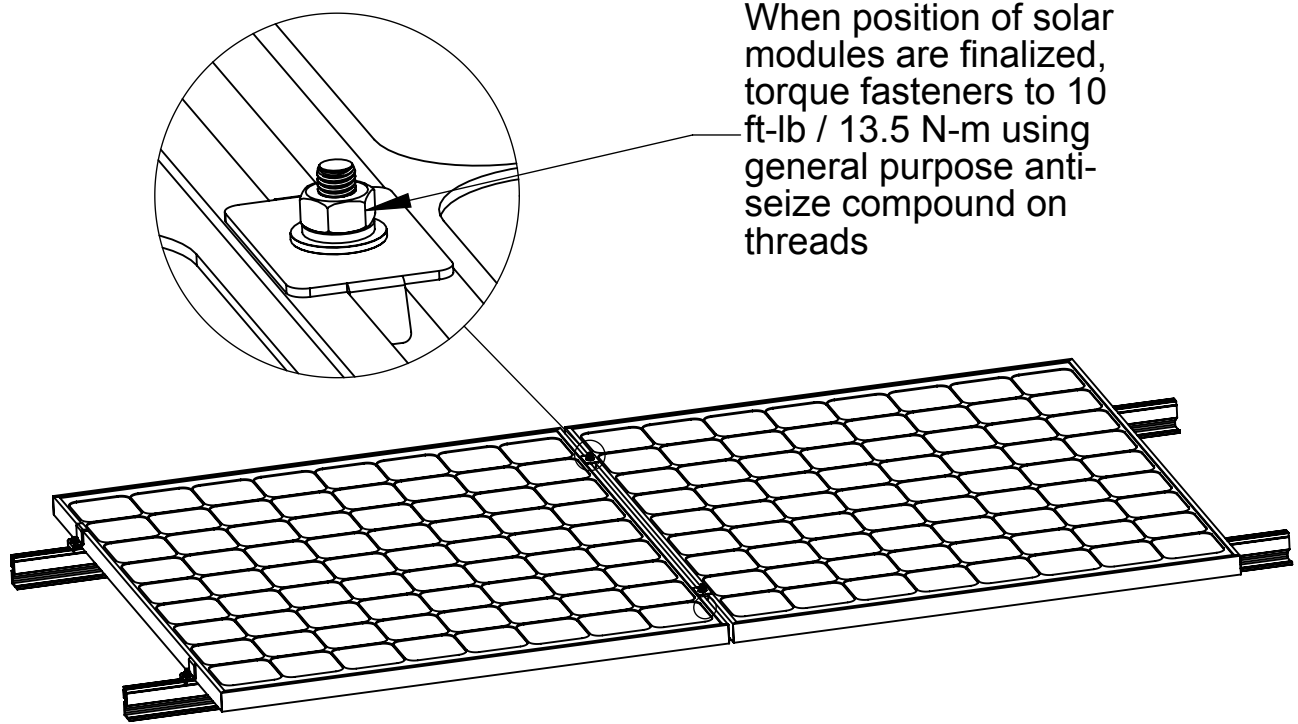

WEEB-DMC LAYOUT

6

EVEN NUMBER OF MODULES IN ROW

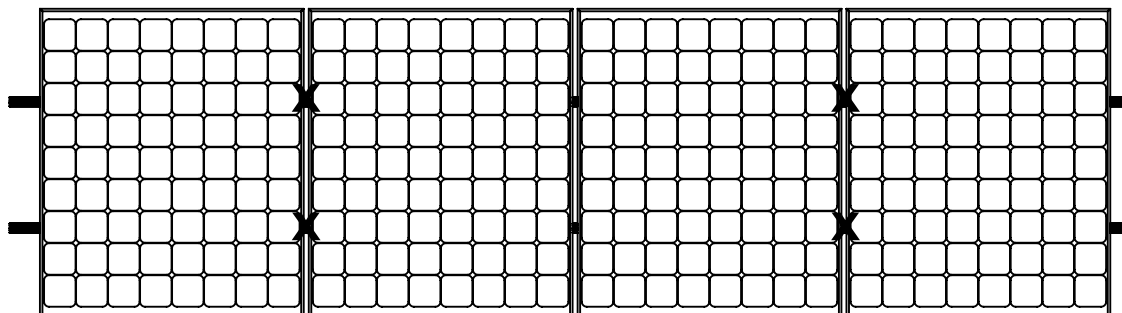

X DENOTES PLACES TO INSTALL WEEB-DMC

$$C \times R = 4 \times 1$$

$$\text{WEEB-DMC NEEDED} = C \times R = 4 \times 1 = 4$$

ODD NUMBER OF MODULES IN ROW

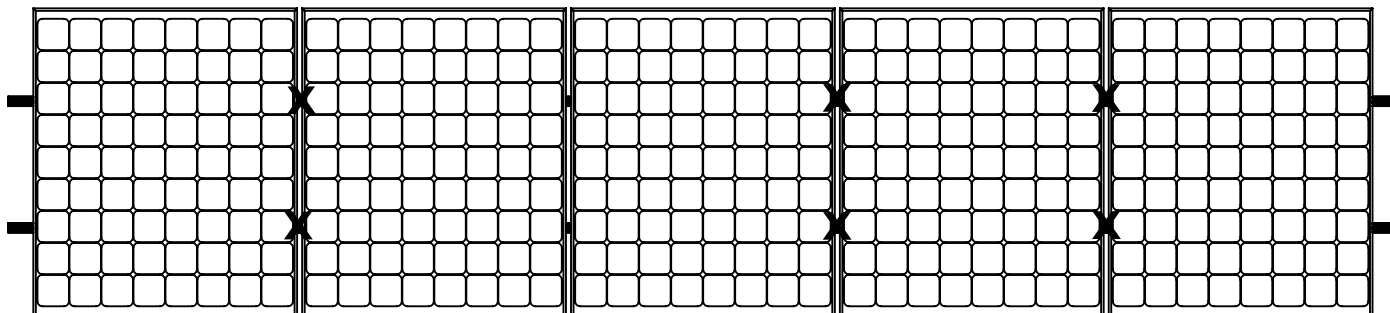

X DENOTES PLACES TO INSTALL WEEB-DMC

$$C \times R = 5 \times 1$$

$$\text{WEEB-DMC NEEDED} = [C+1] \times R = [5+1] \times 1 = 6$$

Note:

When replacing a single faulty module, also remove the adjacent module which contacts the same WEEBs as the faulty module. This will ensure that there are never ungrounded modules in the array.

7

WEEBLUG ASSEMBLY

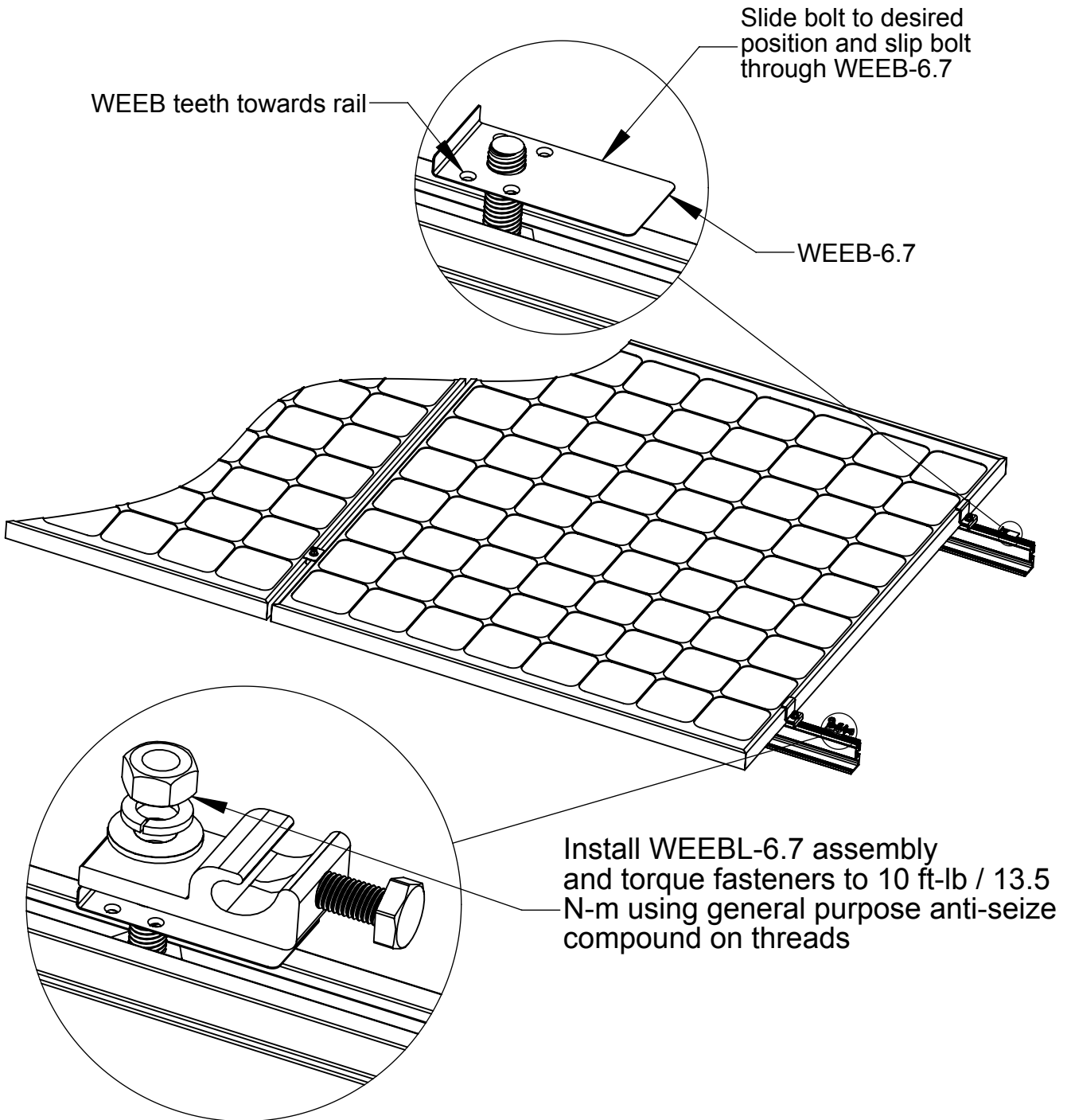

Important note:
WEEB-6.7 that sits under the WEEBLug is for single use only.
Ensure position is correct before tightening down.

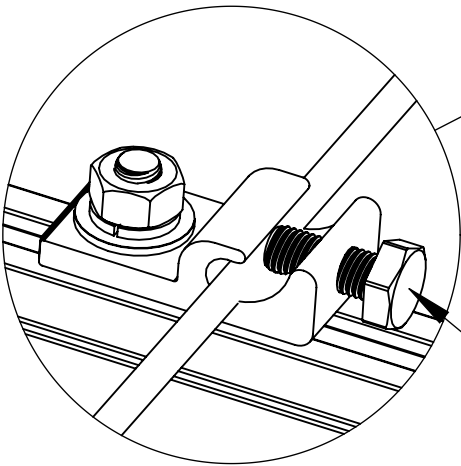
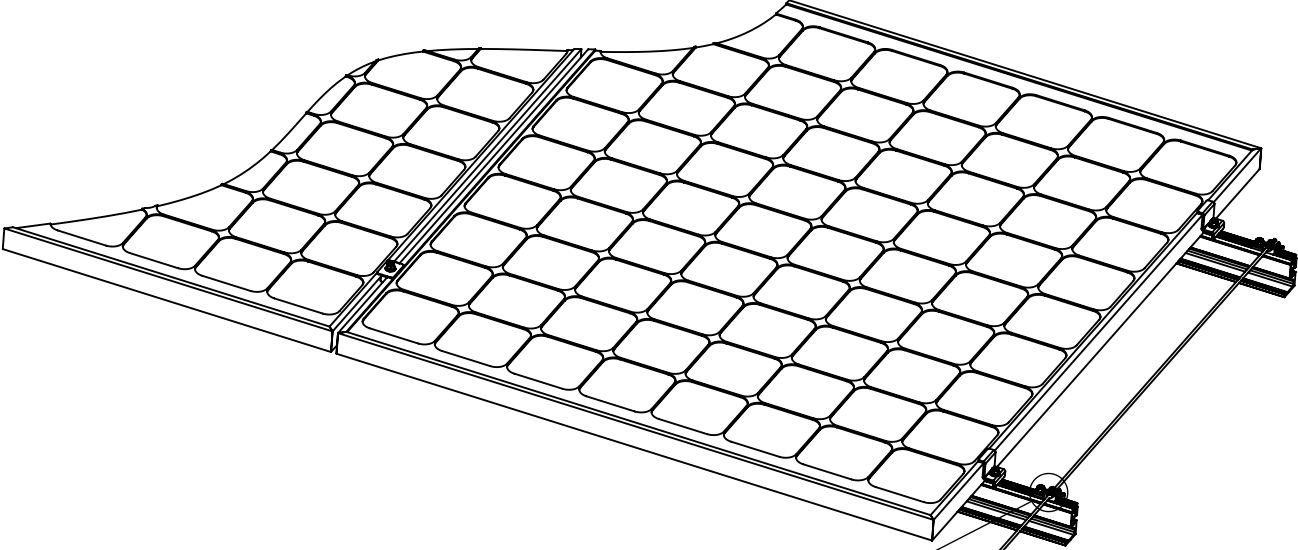

Equipment
Ground
Conductor

Lay in equipment ground conductor
and torque bolt to 7 ft-lb / 10 N-m

DMC SPLICE KIT ASSEMBLY

- ⑨ The flexible WEEB Bonding Jumper can be mounted in different ways shown below.

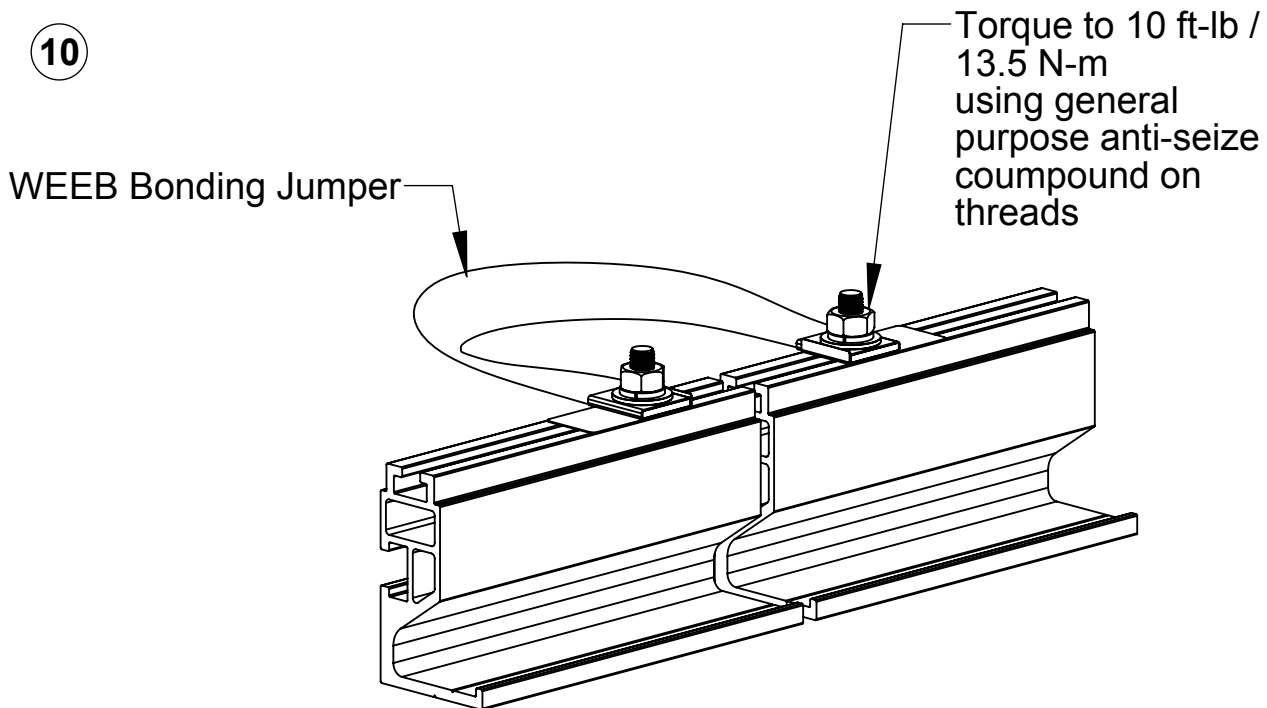
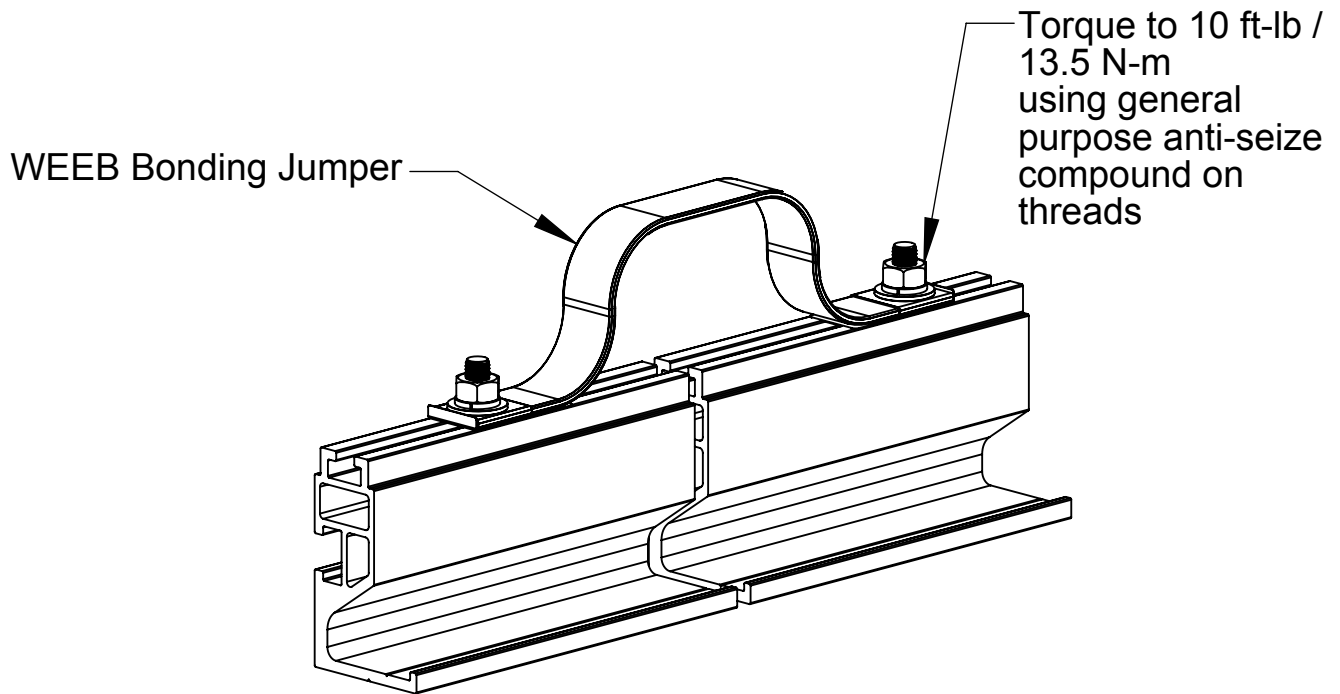

Route WEEB Bonding Jumper as shown above if edge of solar module lands between two splice rails.

LOW-LIPPED MODULE INSTALLATION

11

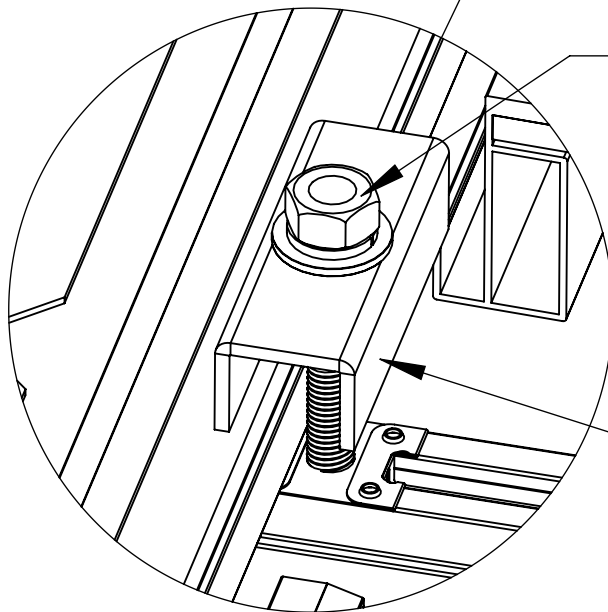
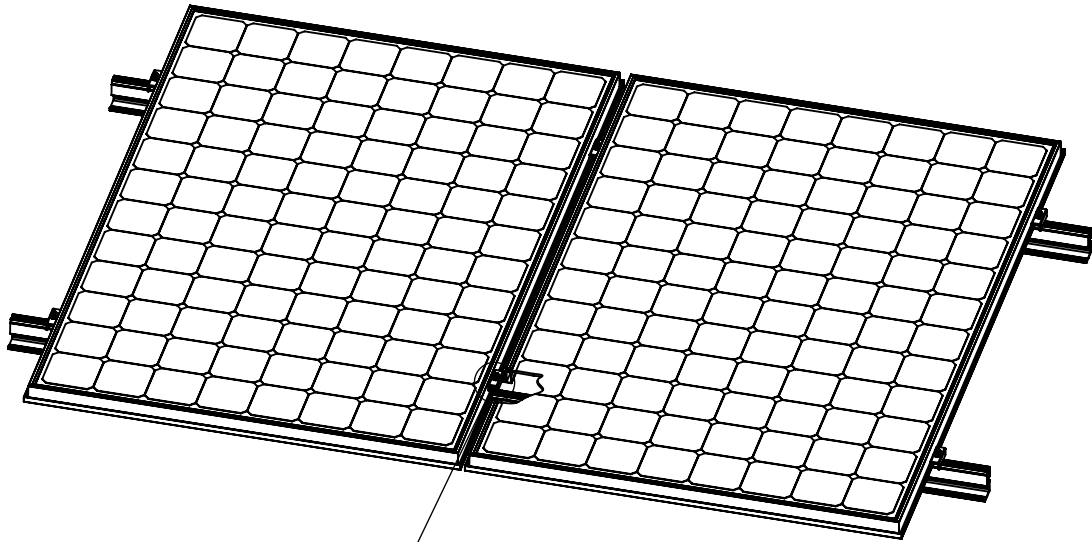

Torque to 10 ft-lb / 13.5 N-m using general purpose anti-seize compound on threads

Inverted U-shaped mid-clamp