



# User Manual

## Grid-Tied PV Inverter

MS Series

5.0-11.4kW G3(US)

V1.3-2023-09-20

**Copyright ©GoodWe Technologies Co., Ltd., 2023. All rights reserved**

No part of this manual can be reproduced or transmitted to the public platform in any form or by any means without the prior written authorization of GoodWe Technologies Co., Ltd.

**Trademarks**

 **GOODWE** and other GOODWE trademarks are trademarks of GoodWe Technologies Co.,Ltd. All other trademarks or registered trademarks mentioned in this manual are owned by GoodWe Technologies Co.,Ltd.

**NOTICE**

The information in this user manual is subject to change due to product updates or other reasons. This guide cannot replace the product labels or the safety precautions in the user manual unless otherwise specified. All descriptions here are for guidance only.

# CONTENT

- 1 About This Manual ..... 1**
  - 1.1 Applicable Model..... 1
  - 1.2 Target Audience ..... 1
  - 1.3 Symbol Definition ..... 2
  - 1.4 Updates..... 2
- 2 IMPORTANT SAFETY INSTRUCTIONS ..... 3**
  - 2.1 General Safety ..... 3
  - 2.2 DC Side..... 3
  - 2.3 AC Side ..... 4
  - 2.4 Inverter Installation..... 4
  - 2.5 Personal Requirements..... 5
- 3 Product Introduction ..... 6**
  - 3.1 Application Scenarios ..... 6
  - 3.2 Circuit Diagram..... 6
  - 3.3 Supported Grid Types ..... 7
  - 3.4 Inverter Operation Mode..... 8
  - 3.5 Functionality..... 9
  - 3.6 Appearance..... 9
    - 3.6.1 Parts ..... 9
    - 3.6.2 Dimensions..... 10
    - 3.6.3 Indicators ..... 10
    - 3.6.4 Nameplate ..... 11
- 4 Check and Storage ..... 12**
  - 4.1 Check Before Receiving..... 12
  - 4.2 Deliverables..... 12
  - 4.3 Storage..... 13
- 5 Installation..... 14**
  - 5.1 Installation Requirements ..... 14
  - 5.2 Inverter Installation..... 17
    - 5.2.1 Moving the Inverter ..... 17

<b>6</b>	<b>Electrical Connection</b>	<b>18</b>
6.1	Safety Precaution	18
6.2	Preparations before Installation	19
6.2.1	Terminal Introduction	19
6.2.1	Cable Specification	19
6.3	Opening the wiring cover	21
6.3	Connecting the PV Input Cable	21
6.4	Connecting the AC Output Cable	22
6.5	Communication	24
6.5.1	Communication Network Introduction	24
6.5.2	Connecting the Communication Cable	25
6.5.3	Installing the WiFi Module (optional)	27
6.5.4	Connecting the antenna(optional)	27
<b>7</b>	<b>Equipment Commissioning</b>	<b>28</b>
7.1	Check Before Power ON	28
7.2	Power On	28
<b>8</b>	<b>System Commissioning</b>	<b>29</b>
8.1	Indicators and Buttons	29
8.3	Upgrading the Firmware Via USB Flash Disk	30
8.4	Setting Inverter Parameters via SolarGo App	30
8.4	Monitoring via SEMS Portal	30
<b>9</b>	<b>Maintenance</b>	<b>31</b>
9.1	Power Off the Inverter	31
9.2	Removing the Inverter	31
9.3	Disposing of the Inverter	31
9.4	Troubleshooting	31
9.5	Routine Maintenance	39
<b>10</b>	<b>Technical Parameters</b>	<b>40</b>
<b>11</b>	<b>Appendix</b>	<b>45</b>
11.1	Precision of inverter parameters	45

# 1 About This Manual

This manual describes the product information, installation, electrical connection, commissioning, troubleshooting, and maintenance. Read through this manual before installing and operating the product. All the installers and users have to be familiar with the product features, functions, and safety precautions. This manual is subject to update without notice. For more product details and latest documents, visit <https://en.goodwe.com>.

## 1.1 Applicable Model

This manual applies to the listed inverters below (MS G3 for short):



Model	Nominal Output Power	Nominal Output Voltage
GW5000-MS-US30	5000W	240V
	4333W	208V
GW6000-MS-US30	6000W	240V
	5200W	208V
GW7600-MS-US30	7600W	240V
	6580W	208V
GW7700-MS-US30	7680W	240V
	6650W	208V
GW9600-MS-US30	9600W	240V
	8320W	208V
GW11K4-MS-US30	11400W	240V
	9880W	208V

## 1.2 Target Audience

This manual applies to trained and knowledgeable technical professionals. The technical personnel has to be familiar with the product, local standards, and electric systems.

## 1.3 Symbol Definition

Different levels of warning messages in this manual are defined as follows:

 <b>DANGER</b>
Indicates a high-level hazard that, if not avoided, will result in death or serious injury.
 <b>WARNING</b>
Indicates a medium-level hazard that, if not avoided, could result in death or serious injury.
 <b>CAUTION</b>
Indicates a low-level hazard that, if not avoided, could result in minor or moderate injury.
<b>NOTICE</b>
Highlight and supplement the texts. Or some skills and methods to solve product-related problems to save time.

## 1.4 Updates

The latest document contains all the updates made in earlier issues.

### V1.0 2022-08-20

- First Issue

### V1.1 2023-02-25

- Add new model: GW7700-MS-US30
- Update **3.3** Supported Grid Types,
- Update **6.5.1** Communication Network Introduction.

### V1.2 2023-04-15

- Update **6.5.1** Communication Network Introduction.
- Update **10** Technical Parameters.

### V1.3 2023-09-20

- Update **6.5.2** Connecting the Communication Cable.

## 2 IMPORTANT SAFETY INSTRUCTIONS

### SAVE THESE INSTRUCTIONS

Please strictly follow these safety instructions in the user manual during the operation.

#### NOTICE

The inverters are designed and tested strictly complies with related safety rules. Read and follow all the safety instructions and cautions before any operations. Improper operation might cause personal injury or property damage as the inverters are electrical equipment.

### 2.1 General Safety

#### NOTICE

- The information in this user manual is subject to change due to product updates or other reasons. This guide cannot replace the product labels or the safety precautions in the user manual unless otherwise specified. All descriptions here are for guidance only.
- Before installations, read through the quick installation guide. For additional information, please see the user manual.
- All installations should be performed by trained and knowledgeable technicians who are familiar with local standards and safety regulations.
- Use insulating tools and wear personal protective equipment when operating the equipment to ensure personal safety. Wear anti-static gloves, cloths, and wrist strips when touching electron devices to protect the inverter from damage.
- Strictly follow the installation, operation, and configuration instructions in this manual. The manufacturer shall not be liable for equipment damage or personal injury if you do not follow the instructions. For more warranty details, please visit <https://en.goodwe.com/warranty>.

### 2.2 DC Side

#### DANGER

Connect the DC cables using the delivered PV connectors. The manufacturer shall not be liable for the equipment damage if other connectors or terminals are used.

#### WARNING

- Ensure the component frames and the bracket system are securely grounded.
- Ensure the DC cables are connected tightly, securely and correctly.
- Measure the DC cable using the multimeter to avoid reverse polarity connection. Also, the voltage should be under the permissible range.
- Do not connect the same PV to multiple inverters. Otherwise, the inverters may be damaged.

### 2.3 AC Side









**⚠ WARNING**

- The voltage and frequency at the connection point meet the inverter grid connection requirements
- Additional protective devices like circuit breakers or fuses are recommended on the AC side. Specification of the protective device should be at least 1.25 times the rated AC output rated current.
- Make sure that all the groundings are tightly connected. When there are multiple inverters, make sure that all the grounding points on the enclosures are equipotential bonding.
- You are recommended to use copper cables as AC output cables. Contact the manufacturer if you want to use other cables.

### 2.4 Inverter Installation

**⚠ DANGER**

- Do not apply mechanical load to the terminals, otherwise the terminals can be damaged.
- All labels and warning marks should be visible after the installation. Do not scrawl, damage, or cover any label on the device.
- For 240V Delta AC Grid, inverters should not be installed in multiple phase combination.
- Warning labels on the inverter are as follows.

	<p>DANGER High voltage hazard. Disconnect all incoming power and turn off the product before working on it.</p>		<p>Delayed discharge. Wait 5 minutes after power off until the components are completely discharged.</p>
	<p>Read through the user manual before working on this device.</p>		<p>Potential risks exist. Wear proper PPE before any operations.</p>
	<p>High-temperature hazard. Do not touch the product under operation to avoid being burnt.</p>		<p>Grounding point.</p>
	<p>SGS Marking for the United States of America and Canada.</p>		<p>Do not dispose of the inverter as household waste. Discard the product in compliance with local laws and regulations, or send it back to the manufacturer.</p>
	<p>Support Type 1 DC Arc detection on PV side.</p>	<p>-</p>	<p>-</p>



## 2.5 Personal Requirements

### NOTICE

- Personnel who install or maintain the equipment must be strictly trained, learn about safety precautions and correct operations.
- Only qualified professionals or trained personnel are allowed to install, operate, maintain, and replace the equipment or parts.

### 3 Product Introduction

#### 3.1 Application Scenarios

The MS G3 inverter is a single-phase PV string grid-tied inverter, which converts the DC power generated by the PV module into AC power for loads or the grid. The intended use of the inverter is as follows:

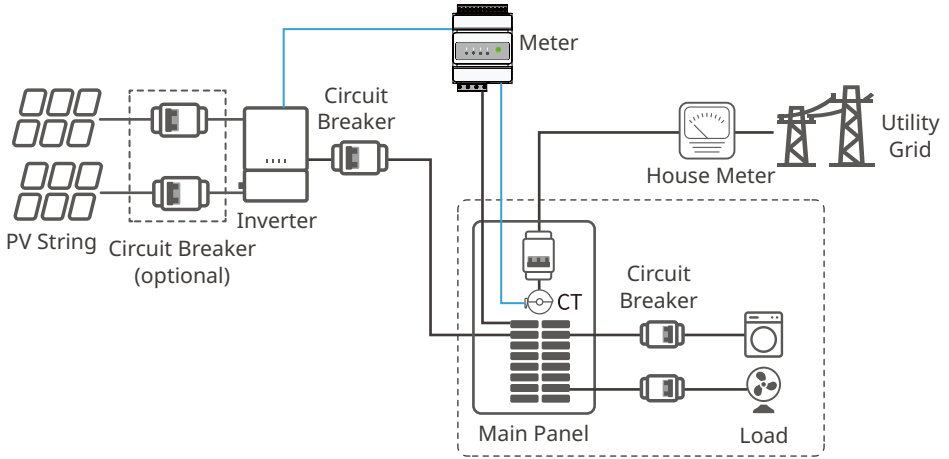

#### 3.2 Circuit Diagram

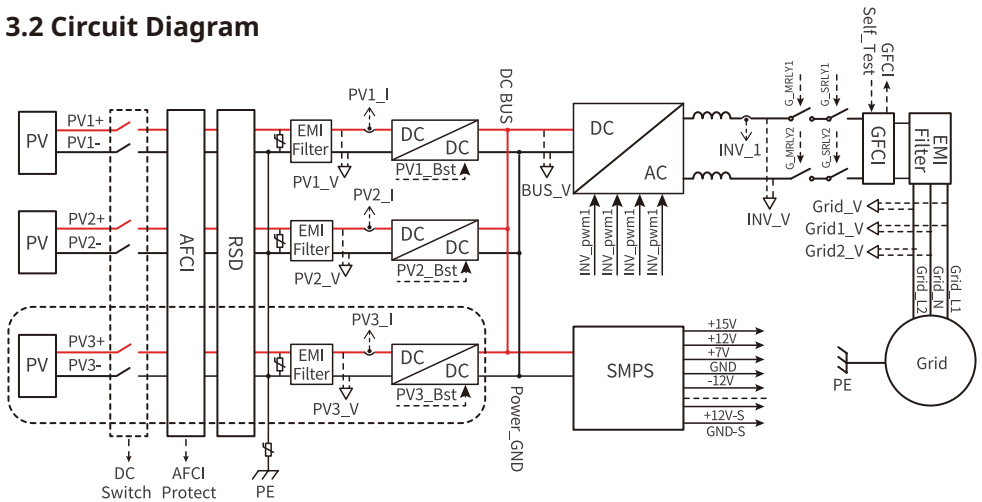

PV3 only for GW7700-MS-US30, GW9600-MS-US30, GW11K4-MS-US30.

### 3.3 Supported Grid Types

The inverter supports 240V/120V Split Phase AC Grid and 208V Delta AC Grid.

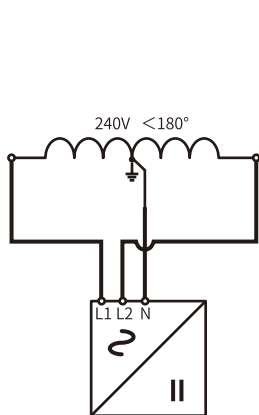

240V/120V Split Phase AC Grid

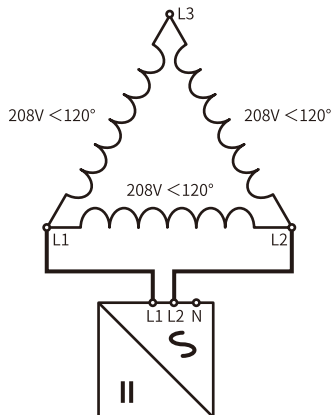

208V Delta AC Grid

### 3.4 Inverter Operation Mode

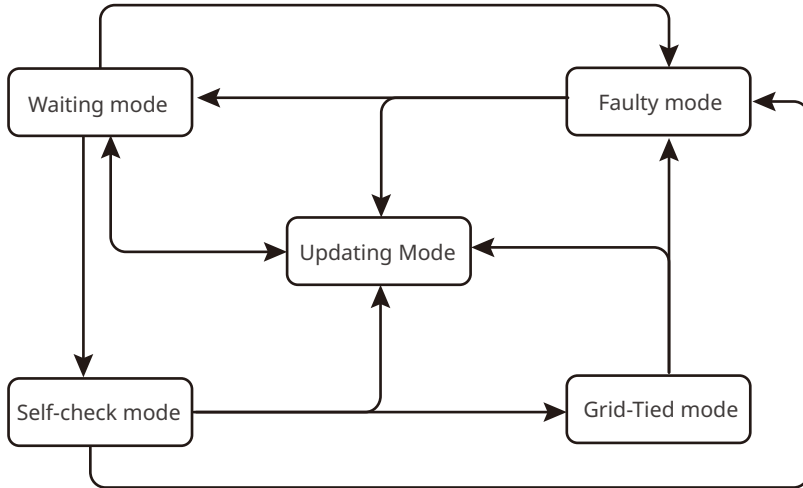

No.	Parts	Description
1	Waiting mode	Waiting stage after the inverter is powered on. <ul style="list-style-type: none"> <li>When the conditions are met, it enters the self-check mode.</li> <li>If there is a fault, the inverter enters the fault mode.</li> <li>If an updating request is received, the inverter enters the updating mode.</li> </ul>
2	Self-check mode	Before the inverter starts up, it continuously performs self-check, initialization, etc. <ul style="list-style-type: none"> <li>When the conditions are met, it enters the grid-tied mode, and the inverter starts on grid connection.</li> <li>If an updating request is received, the inverter enters the updating mode.</li> <li>If the self-check is not passed, it enters the fault mode.</li> </ul>
3	Grid-Tied mode	The inverter is grid-tied successfully, making energy conversion and controlling the power in PV systems. <ul style="list-style-type: none"> <li>If a fault is detected, it enters the fault mode.</li> <li>If an updating request is received, the inverter enters the updating mode.</li> </ul>
4	Faulty mode	If a fault is detected, the inverter enters the fault mode. When the fault is cleared, it enters the wait mode.
5	Updating Mode	When the inverter is upgrading the program, it enters the updating mode. <ul style="list-style-type: none"> <li>When the upgrading is finished, it enters the waiting mode.</li> </ul>

### 3.5 Functionality

#### Ezlink

The inverter has a built-in Ezlink module supporting IEEE2030.5 communication protocol. It supports setting the inverter via Bluetooth in a short distance; connecting to the server via 4G, WiFi or LAN to monitor the inverter and power plant operation, etc.

- Bluetooth: meets Bluetooth 5.1 standard.
- 4G (optional): supports AT&T and T-Mobile mainstream service provider.
- WiFi: supports 2.4G frequency band. Set the router to 2.4G or 2.4G/5G coexistence mode (User can set 40 bytes for router wireless signal name maximumly.)
- LAN (optional): supports connecting to the router via LAN communication and then connecting to the server.

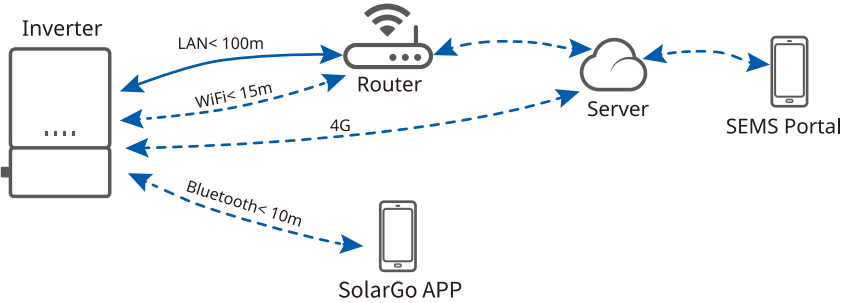

### 3.6 Appearance

#### 3.6.1 Parts

Back view of MS G3 inverter

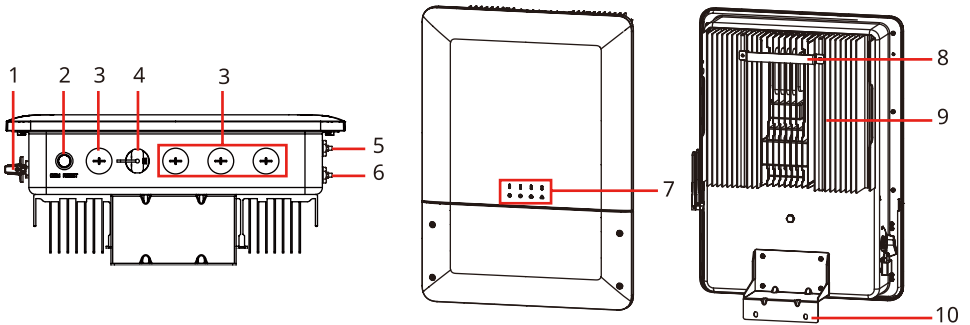

No.	Parts	Description
1	DC Switch	Start or stop DC input.
2	Ezlink Reset Button	Optical, able to reset the Ezlink.
3	Cable Hole	Inverter cable inlet and outlet.
4	COM Module Port	Optical, able to be connected with WiFi module.
5	Port for WiFi/BT antenna	Able to be connected with WiFi or BT antenna.
6	Port for 4G antenna	Optical, able to be connected with 4G antenna.
7	Indicator	Indicates working state of the inverter.

No.	Parts	Description
8	Mounting Plate	Used to install the inverter.
9	Heat sink	Used to cool the inverter.
10	Inverter fixing part	Used to fix the inverter.

### 3.6.2 Dimensions

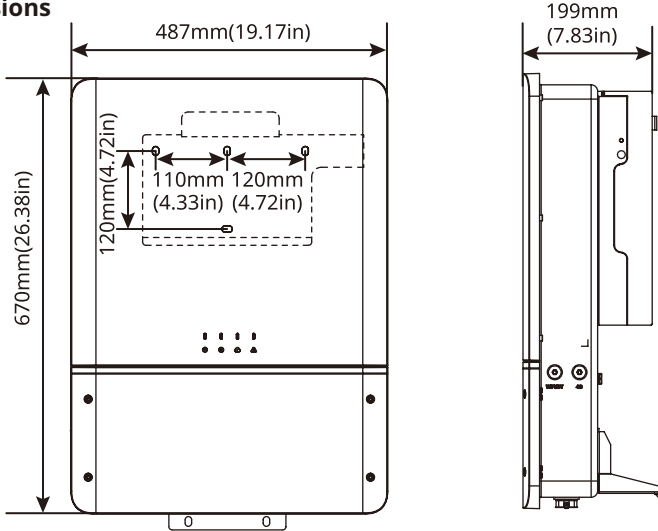



### 3.6.3 Indicators

Indicator	Status	Description
⏻		ON = Equipment Power On
		OFF = Equipment Power Off
▶		ON = The Inverter Is Feeding Power
		OFF = The inverter is not feeding power
		Single slow flash = Self check before connecting to the grid
		Single flash = Connecting to the grid
☁		ON = Wireless is connected/active
		Blink 1 = Wireless system is resetting
		Blink 2 = Wireless router not connected
		Blink 4 = Wireless server problem
		Blink = RS485 is connected
		OFF = Wireless is not active
⚠		ON = A fault has occurred
		OFF = No fault

### 3.6.4 Nameplate

The nameplate is for reference only.

<b>Product: Grid-Tied PV Inverter</b> <b>Model : ****_**_**</b>
Vmax PV: ***Vd.c. MPPT voltage range: **...***Vd.c. Max. PV current: **/**Ad.c. Isc PV: **/**Ad.c.
Rated grid voltage: ***Va.c. Output voltage range: ***-***Va.c. AC-grid frequency: **Hz AC-grid frequency range: **-**Hz Max current: **Aa.c. Rated active power: ***Va.c. Rated apparent power: ***Va.c. Max apparent power: ***Va.c.
Power factor range: ~*,*cap...*ind Operating temperature range: -**~**°F(**°C~**°C) Derating temperature: ****F(**°C) Grid Support Utility Interactive Inverter Transformerless Type 4X, PV DC AFCI: Type 1 Contains FCC ID:*****-**
 
S/N:  ***** Co.,Ltd. *****@***.com ***** S/N

GW trademark, product type, and product model

Technical parameters

Safety symbols and certification marks

Contact information and serial number

## 4 Check and Storage

### 4.1 Check Before Receiving

Check the following items before receiving the product.

1. Check the outer packing box for damage, such as holes, cracks, deformation, and other signs of equipment damage. Do not unpack the package and contact the supplier as soon as possible if any damage is found.
2. Check the inverter model. If the inverter model is not what you requested, do not unpack the product and contact the supplier.
3. Check the deliverables for correct model, complete contents, and intact appearance. Contact the supplier as soon as possible if any damage is found.

### 4.2 Deliverables

#### WARNING

Connect the DC cables with the delivered terminals. The manufacturer shall not be liable for the damage if other terminals are used.

#### NOTICE

The antenna and the WiFi module are shipped according to the communication mode supported by the inverter.

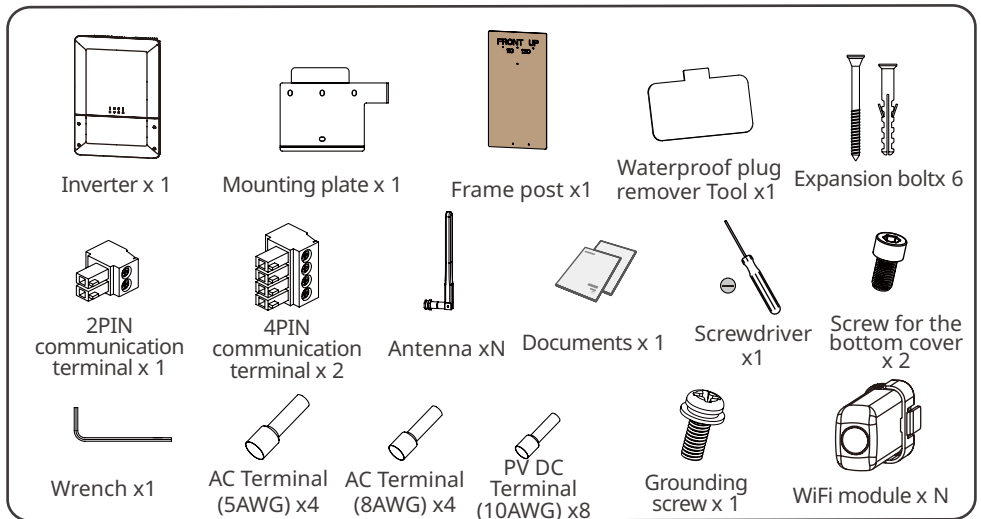



## 4.3 Storage

If the equipment is not to be installed or used immediately, please ensure that the storage environment meets the following requirements:

1. Do not unpack the outer package or throw the desiccant away.
2. Store the equipment in a clean place. Make sure the temperature and humidity are appropriate and no condensation.
3. The height and direction of the stacking inverters should follow the instructions on the packing box.
4. The inverters must be stacked with caution to prevent them from falling.
5. If the inverter has been long term stored, it should be checked by professionals before being put into use.

## 5 Installation

### 5.1 Installation Requirements

#### Installation Environment Requirements

1. Do not install the equipment in a place near flammable, explosive, or corrosive materials.
2. Install the equipment on a surface that is solid enough to bear the inverter weight.
3. Install the equipment in a well-ventilated place to ensure good dissipation. Also, the installation space should be large enough for operations.
4. The equipment with a high ingress protection rating can be installed indoors or outdoors. The temperature and humidity at the installation site should be within the appropriate range.
5. Install the equipment in a sheltered place to avoid direct sunlight, rain, and snow. Build a sunshade if it is needed.
6. Install the equipment in a well-ventilated place to ensure good dissipation. Also, the installation space should be large enough for operations.
7. Do not install the equipment in a place that is easy to touch, especially within children's reach. High temperature exists when the equipment is working. Do not touch the surface to avoid burning.
8. Install the equipment at a height that is convenient for operation and maintenance, electrical connections, and checking indicators and labels.
9. The altitude to install the inverter shall be lower than the maximum working altitude 3000m(9842ft).
10. The inverter is easy to be corroded when installed in salt areas. Please consult the inverter manufacturer before installing it outdoors in salt areas. A salt area refers to the region within 1000m(3281ft) offshore or affected by the sea breeze. The area prone to the sea breeze varies depending on weather conditions (e.g. typhoon, monsoon) or terrain (such as dams and hills).
11. Install the inverter away from high magnetic field to avoid electromagnetic interference. If there is any radio or wireless communication equipment below 30MHz near the inverter, you have to:
  - Install the inverter at least 30m(98.43ft) far away from the wireless equipment.
  - Add a low pass EMI filter or a multi winding ferrite core to the DC input cable or AC output cable of the inverter.



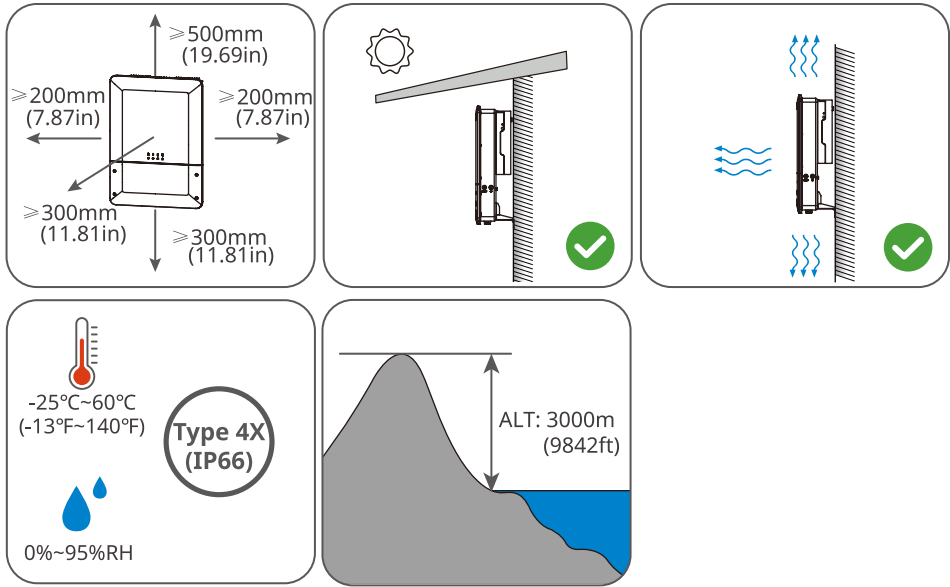

### Mounting Support Requirements

- The mounting support shall be nonflammable and fireproof.
- Make sure that the support surface is solid enough to bear the product weight load.
- Do not install the product on the support with poor sound insulation to avoid the noise generated by the working product, which may annoy the residents nearby.

### Installation Angle Requirements

- Install the inverter vertically or at a maximum back tilt of 15 degrees.
- Do not install the inverter upside down, forward tilt, back forward tilt, or horizontally.

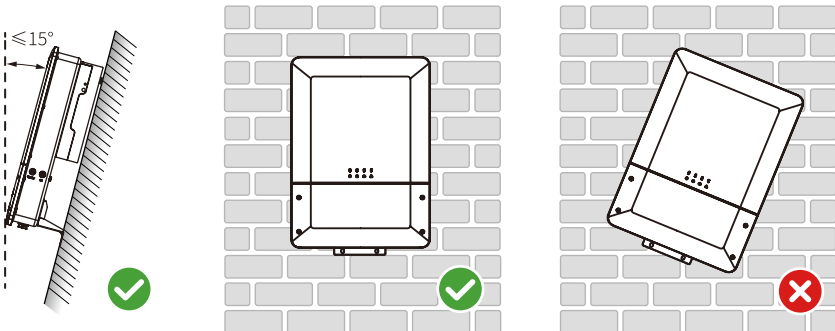

### Installation Tool Requirements

The following tools are recommended when installing the equipment. Use other auxiliary tools on site if necessary.

 Goggles	 Safety shoes	 Safety gloves	 Dust mask	 DC wiring wrench
 Diagonal pliers	 Wire stripper	 Hammer drill	 Heat gun	 Vacuum cleaner
 Marker	 Level	 Heat shrink tube	 Rubber hammer	 Multimeter
 Cable tie	 Torque wrench M3/M5	 DC/AC terminal crimping tool		

## 5.2 Inverter Installation

### 5.2.1 Moving the Inverter

#### CAUTION

- Operations such as transportation, turnover, installation and so on must meet the requirements of the laws and regulations of the country or region where it is located.
- Move the inverter to the site before installation. Follow the instructions below to avoid personal injury or equipment damage.
  1. Consider the weight of the equipment before moving it. Assign enough personnel to move the equipment to avoid personal injury.
  2. Wear safety gloves to avoid personal injury.
  3. Keep balance to avoid falling down when moving the equipment.

#### NOTICE

- Avoid the water pipes and cables buried in the wall when drilling holes.
- Wear goggles and a dust mask to prevent the dust from being inhaled or contacting eyes when drilling holes.
- The DC switch lock shall be prepared by customers with hole diameter:  $\varnothing 8\text{mm}$  (0.31in). Select appropriate size. Otherwise it is unable to finish the installation.
- The anti-theft lock shall be prepared by customers with hole diameter:  $\varnothing 10\text{mm}$  (0.39in). Select appropriate size. Otherwise it is unable to finish the installation.
- Make sure the inverter is firmly installed in case of falling down.

**Step 1** Put the mounting plate on the wall or the support horizontally and mark positions for drilling holes.

**Step 2** Drill holes to a depth of 80mm (3.15in) using the hammer drill. The diameter of the drill bit should be 10mm (0.39in).

**Step 3** Secure the mounting plate using the expansion bolts.

**Step 4** Secure the DC switch with the DC switch lock, ensuring that the DC switch is "OFF" during installation.

**Step 5** Install the inverter on the mounting plate.

**Step 6** Tighten the nuts to secure the mounting plate and the inverter.

**Step 7** Install the anti-theft lock.

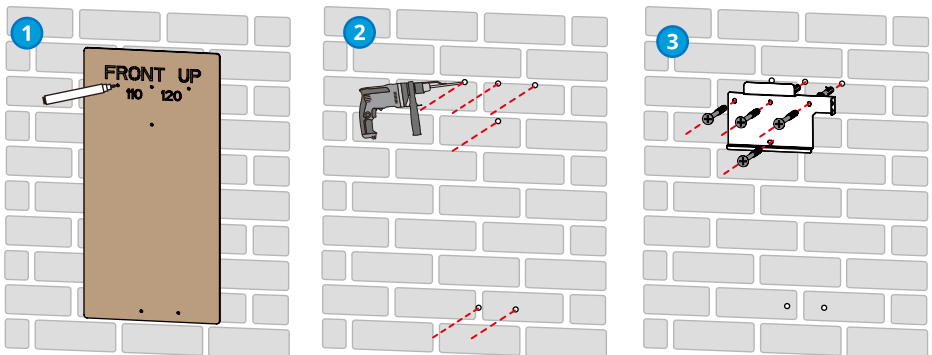

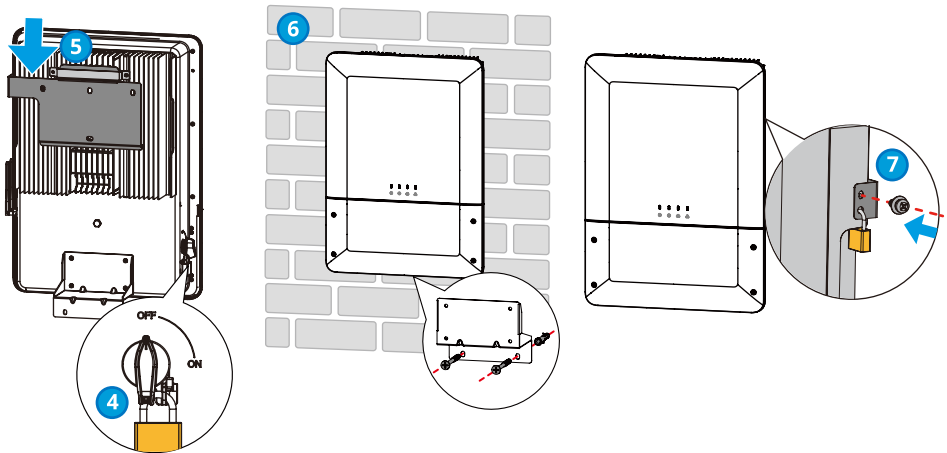

## 6 Electrical Connection

### 6.1 Safety Precaution

#### DANGER

##### INSTRUCTIONS PERTAINING TO A RISK OF FIRE OR ELECTRIC SHOCK

- All operations, cables and parts specification during the electrical connection shall be in compliance with local laws and regulations.
- The input and output circuits are isolated from the enclosure and that system grounding, if required by the National Electric Code, ANSI/NFPA 70, is the responsibility of the installer.
- Disconnect the DC switch and the AC output switch of the inverter to power off the inverter before any electrical connections. Do not work with power on. Otherwise, an electric shock may occur.
- Tie the same type cables together, and place them separately from cables of different types. Do not place the cables entangled or crossed.
- If the cable bears too much tension, the connection may be poor. Reserve a certain length of the cable before connecting it to the inverter cable port.
- When crimping the terminals, ensure that the conductor part of the cable is in full contact with the terminals. Do not crimp the cable jacket with the terminal. Otherwise the inverter may not operate, or its terminal block getting damaged due to heating and other phenomenon because of unreliable connection after operation.

#### WARNING

##### GROUNDING INSTRUCTIONS

- This product must be connected to a grounded, metal, permanent wiring system, or an equipment-grounding conductor must be run with the circuit conductors and connected to the equipment grounding terminal or lead on the product.

#### NOTICE

- Wear personal protective equipment like safety shoes, safety gloves, and insulating gloves during electrical connections.
- All electrical connections should be performed by qualified professionals.
- Cable colors in this document are for reference only. The cable specifications shall meet local laws and regulations.

## 6.2 Preparations before Installation

### 6.2.1 Terminal Introduction

 **WARNING**

- The conduit needs to be provided by the user, and the specification of the conduit used shall match the specification of the waterproof plug.
- It is recommended to use 1 inch cable gland for routing. The diameter for the routing hole on the bottom of the inverter is 34mm (1.34 in).
- When installing the conduit, make sure the installation is in place and the hole between the conduit and the inverter interface is sealed. Otherwise the protection level of the equipment may be affected, which may cause damage to the equipment.

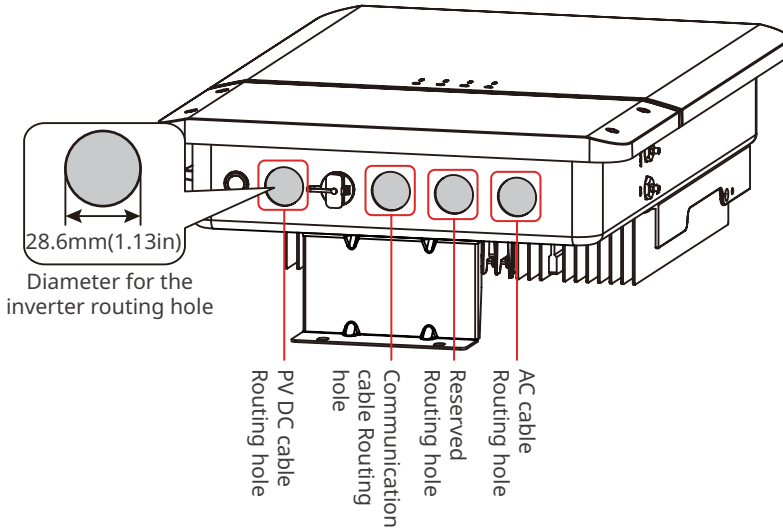

### 6.2.1 Cable Specification

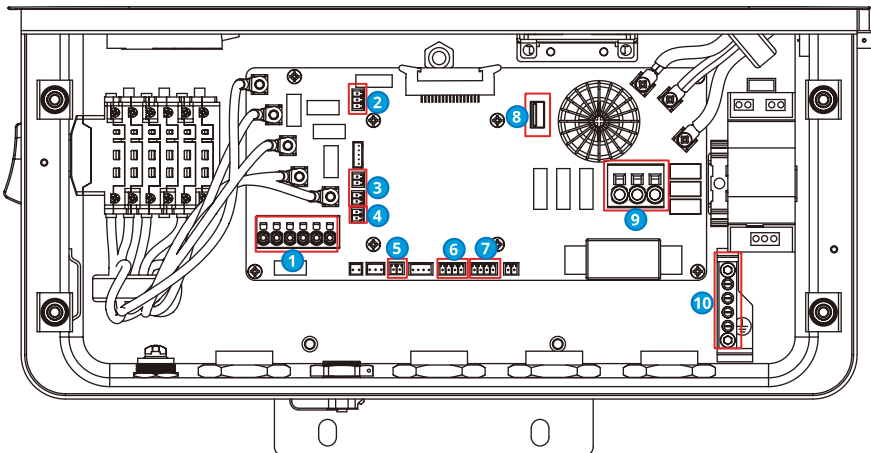

No.	Port	Screen print	Recommended Cable Diameter
1	PV input terminal	PV1+ PV1-	Used to connect the PV module DC input cables <ul style="list-style-type: none"> <li>The recommended cables are: copper wire, temperature 90°C (194°F), 10AWG</li> </ul>
		PV2+ PV2-	
		PV3+ PV3- (only applicable GW7700-MS-US30, GW9600-MS-US30 and GW11K4-MS-US30)	
2	Dry contact communication terminal	DRY-OUT	Reserved port for dry contact function.
3	CT communication terminal	CT2	Reserved port for anti reverse current function.
		CT1	
4	Remote Shutdown communication terminal	DRM0	Used to connect the Remote Shutdown communication cable <ul style="list-style-type: none"> <li>The recommended cables are: outdoor communication cables meeting UL2919, CM/CMG (NEC type) or CMH (CSA type) standards, with conductor cross-sectional area between 24 and 16AWG.</li> </ul>
5	Power supply terminal for RSD module	RSD-12V	Used to connect the RSD module communication cable <ul style="list-style-type: none"> <li>The recommended cables are: outdoor communication cables meeting UL2919, CM/CMG (NEC type) or CMH (CSA type) standards, with conductor cross-sectional area between 24 and 16AWG.</li> </ul>
6	Meter communication terminal	METER	Used to connect the meter communication cable. <ul style="list-style-type: none"> <li>The recommended cables are: outdoor communication cables meeting UL2919, CM/CMG (NEC type) or CMH (CSA type) standards, with conductor cross-sectional area between 24 and 16AWG.</li> </ul>
7	Communication terminal for multi inverter parallel connection	485-1 485-2	Used to connect the RS485 multiple inverters communication cable. <ul style="list-style-type: none"> <li>The recommended cables are: outdoor communication cables meeting UL2919, CM/CMG (NEC type) or CMH (CSA type) standards, with conductor cross-sectional area between 24 and 16AWG.</li> </ul>
8	USB port	USB	The inverter supports connecting with the USB Flash Disk and data cable for local upgrading.
9	AC cable terminal	GRID-L1	Used to connect the inverter AC cable. <ul style="list-style-type: none"> <li>The recommended cables are: copper wire, temperature 90°C (194°F), with conductor cross-sectional area 8-6AWG.</li> </ul>
		GRLD-N	
		GRID-L2	
10	Grounding busbar	-	Connecting the PE cable <ul style="list-style-type: none"> <li>The recommended cables are: copper wire, temperature 90°C (194°F), with conductor cross-sectional area 10-6AWG.</li> </ul>



## 6.3 Opening the wiring cover

### NOTICE

- The wrench for opening the inverter lower case cover is distributed with the inverter. After removing the inverter lower case cover, please keep the wrench and fastening screws properly for later use.
- If you need to open the inverter cover in rain or snow, please take protective measures to prevent rain or snow from entering the maintenance chamber. If it is not able to be guaranteed, do not open the inverter cover.
- It is forbidden to open the inverter upper case cover.

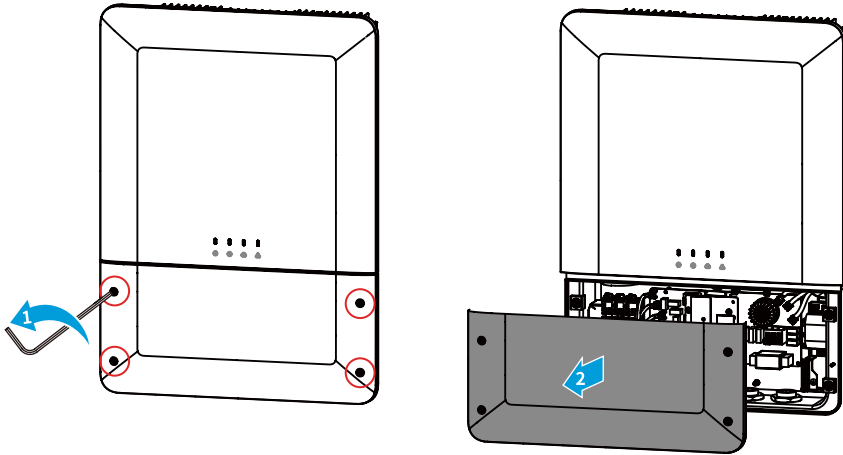

## 6.3 Connecting the PV Input Cable

### DANGER

#### INSTRUCTIONS PERTAINING TO A RISK OF FIRE OR ELECTRIC SHOCK

- Do not connect one PV string to more than one inverter at the same time. Otherwise, it may cause damages to the inverter.
- Confirm the following information before connecting the PV string to the inverter. Otherwise, the inverter may be damaged permanently or even cause fire and cause personal and property losses.
  1. Make sure that the max short circuit current and the max input voltage per MPPT are within the permissible range.
  2. Make sure that the positive pole of the PV string connects to the PV+ of the inverter. And the negative pole of the PV string connects to the PV- of the inverter.

### WARNING

The unit is not provided with an isolation transformer and is intended to be installed per NFPA 70, 690.35 with an ungrounded PV array.

- Step 1** Make the DC output cable.
- Step 2** Disassemble the DC routing hole's end cap.
- Step 3** Use the cable gland for routing wires.
- Step 4** Connect the DC terminals to the inverters.

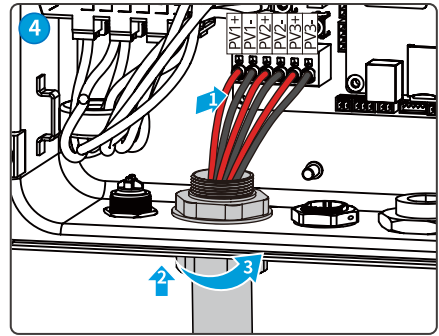
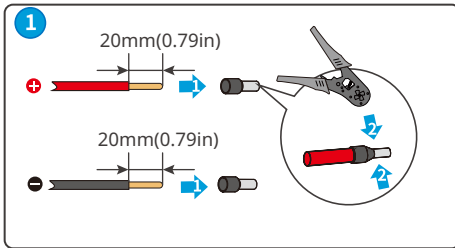
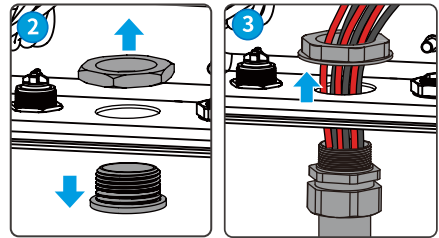
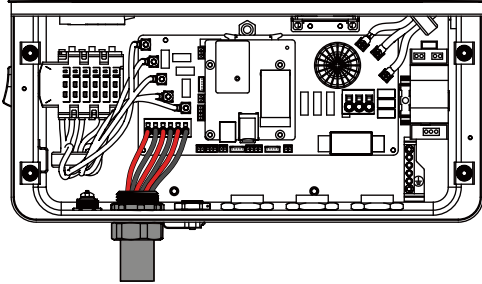

## 6.4 Connecting the AC Output Cable

### ⚠ WARNING

- Do not connect loads between the inverter and the AC switch directly connected to the inverter.
- The Residual Current Monitoring Unit (RCMU) is integrated into the inverter. The inverter will disconnect the utility grid rapidly once it detects any leak current over the permissible range.

### ⚠ WARNING

- Pay attention to the silkscreens L1, L2, N, PE on the AC terminal. Connect the AC cables to the corresponding terminals. The inverter may be damaged if the cables are connected inappropriately.
- Make sure that the whole cable cores are inserted into the AC terminal holes. No part of the cable core can be exposed.
- Make sure that the cables are connected securely. Otherwise, the terminal may be too hot to damage the inverter when the inverter is working.

- Step 1** Make the AC output cable.
- Step 2** Disassemble the DC routing hole's end cap.
- Step 3** Use the cable gland for routing wires.
- Step 4** Plut the AC connector into the inverter.

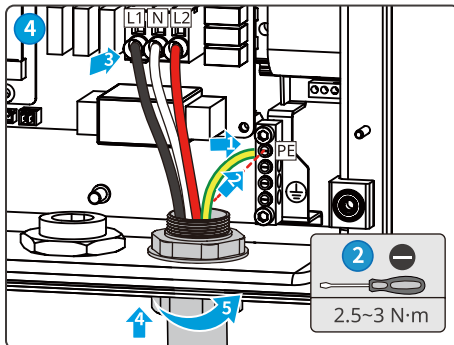
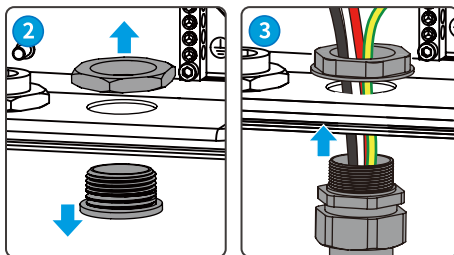
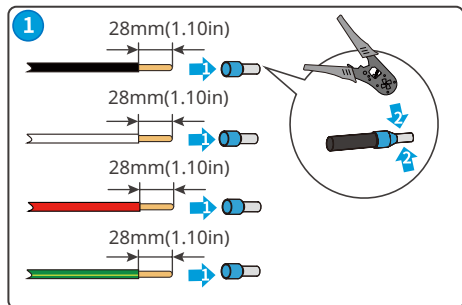
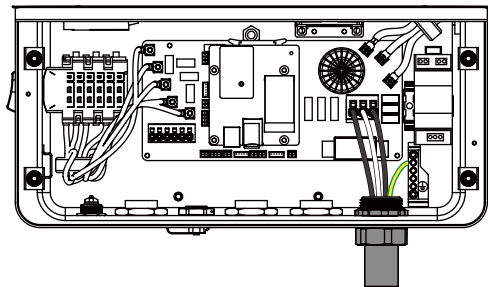

## 6.5 Communication

### 6.5.1 Communication Network Introduction

#### Power Limit Network

The PV station generates power for self-consumption, but the electric equipment cannot consume all the generated power. The inverter can monitor the on-grid electric data in real-time and adjust the output power via a smart meter to avoid the residual current feeding back to the utility grid.

Networking under 240V Nominal Output Voltage

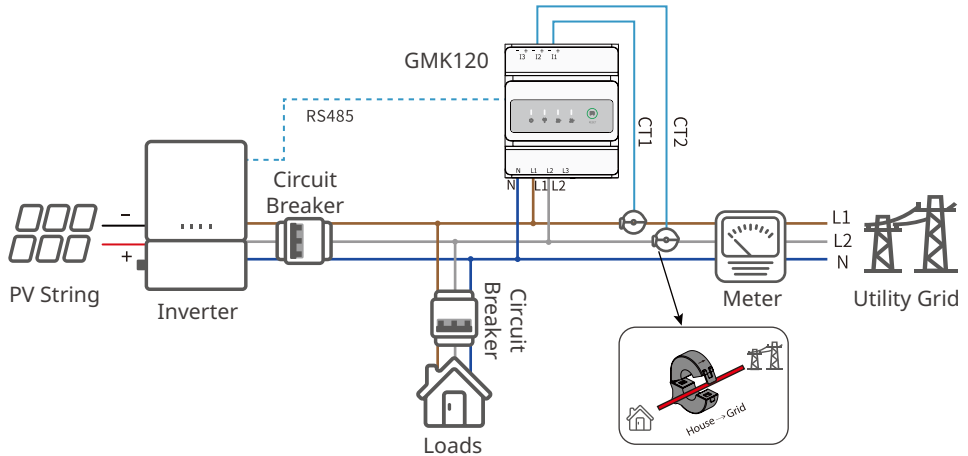

#### NOTICE

After completing cable connections, set related parameters via LCD or SolarGo app to enable export power limit control or output power limit control.

#### Load Monitoring Network

With GMK120, the inverter output data and on-grid data can be accurately measured to calculate the load electricity consumption. The operating data will be uploaded to the Cloud via WiFi or Ezlink communication to realize 24 hours real-time load electricity consumption monitoring.

Networking under 240V Nominal Output Voltage

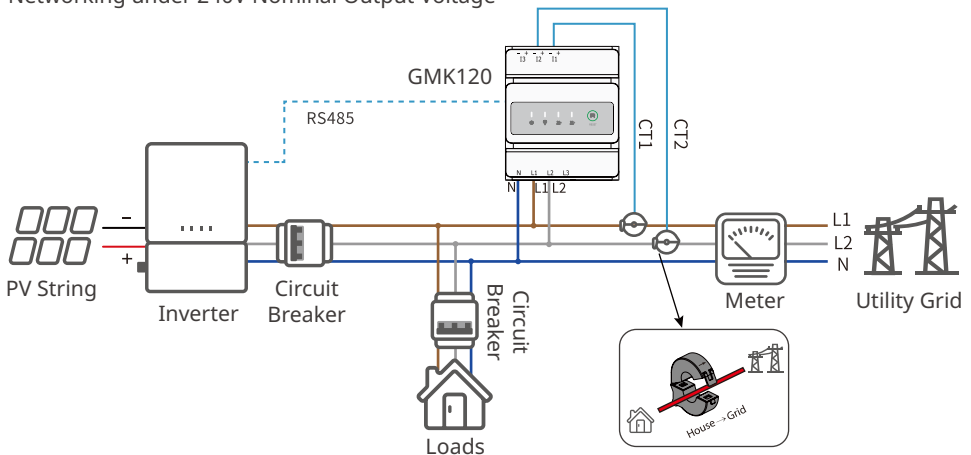

### 6.5.2 Connecting the Communication Cable

#### NOTICE

Make sure that the communication device is connected to the right terminal. Route the communication cable far away from any interference source or power cable to prevent the signal from being influenced.

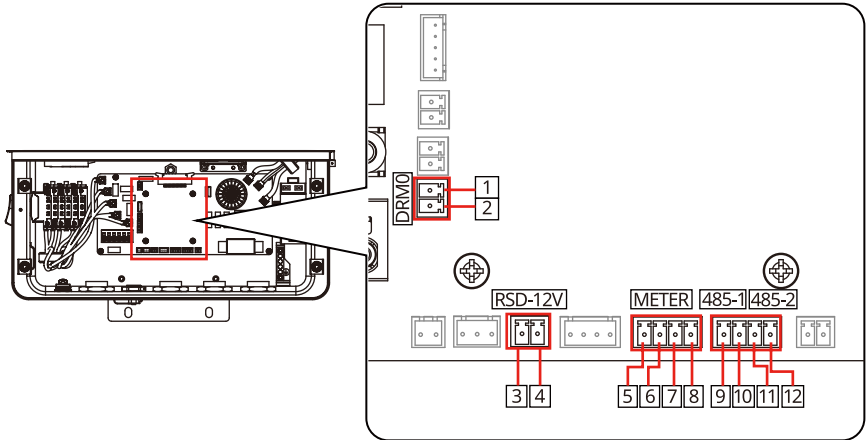

PIN	Function	Definition
1	Remote shutdown	COM/DRM0
2		REFGEN
3	power supply for RSD module	12V-AC_SPS
4		RSD-12V
5	Meter	Meter+
6		Meter-
7		12V+
8		GND
9	parallel connection	RS485-A
10		RS485-B
11		RS485-A
12		RS485-B

**WARNING**

- The communication terminal connected to the power supply port of the RSD switch is equipped with a resistor. When using the RSD function, the resistor needs to be removed and properly stored.
- Do not remove the resistor when the RSD function is not required. Otherwise, the inverter may fail to connect to the power grid.

RSD Wiring Diagram

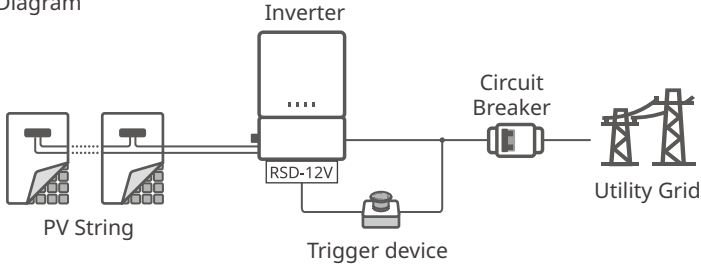

The cables for remote shutdown, smart meter, parallel connection, and power supply for RSD module are connected in the same way. The following illustration shows an example of connecting smart meter communication cable.

- Step 1** Make the communication cable.
- Step 2** Connect the cable with the terminal.
- Step 3** Disassemble the DC routing hole's end cap.
- Step 4** Use the cable gland for routing wires.
- Step 5** Plut the communication connector into the inverter.

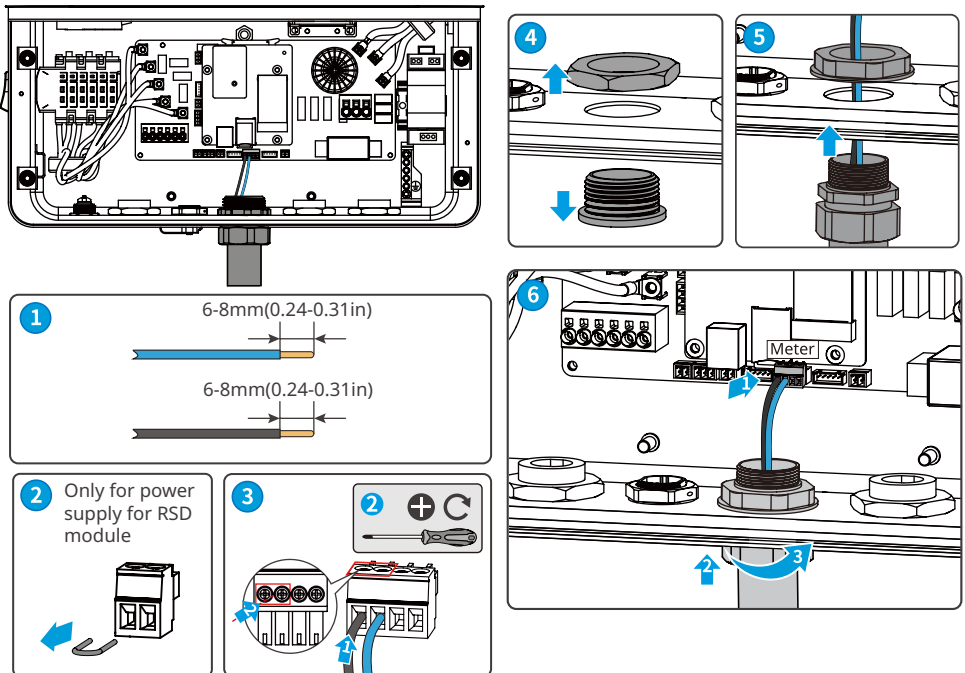

**NOTICE**

- Make sure that the cable is connected correctly and securely. Clear the debris after completing the connection.
- Seal the AC output terminal to ensure the ingress protection rating.

The inverter supports being connected to the smart phone or web pages via Ezlink and WiFi module to set relative parameters, thus to check the inverter's running information, fault information and observe system status in time.

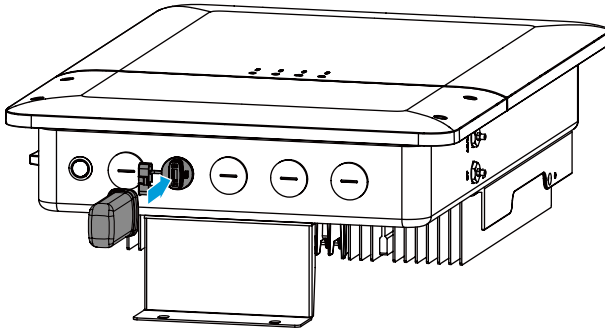
**6.5.3 Installing the WiFi Module (optional)****NOTICE**

Refer to the delivered WiFi module user manual to get more introduction to the module. For more detailed information, visit <https://en.goodwe.com>.

**6.5.4 Connecting the antenna(optional)****NOTICE**

- When an Ezlink is used for device communication, an antenna needs to be installed.
- The 4G, WiFi, and bluetooth antenna are connected in the same way. The following illustration shows an example of installing the 4G antenna.

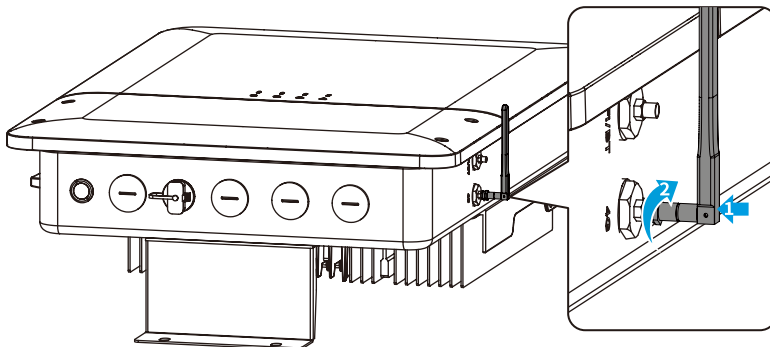

## 7 Equipment Commissioning

### 7.1 Check Before Power ON

No.	Check Item
1	The product is firmly installed at a clean place that is well-ventilated and easy to operate.
2	The PE, DC input, AC output, and communication cables are connected correctly and securely.
3	Cable ties are intact, routed properly and evenly.
4	Unused ports and terminals are sealed.
5	The voltage and frequency at the connection point meet the inverter grid connection requirements.

### 7.2 Power On

**Step 1** Turn on the AC switch between the inverter and the utility grid.

**Step 2** Turn on the DC switch of the inverter.

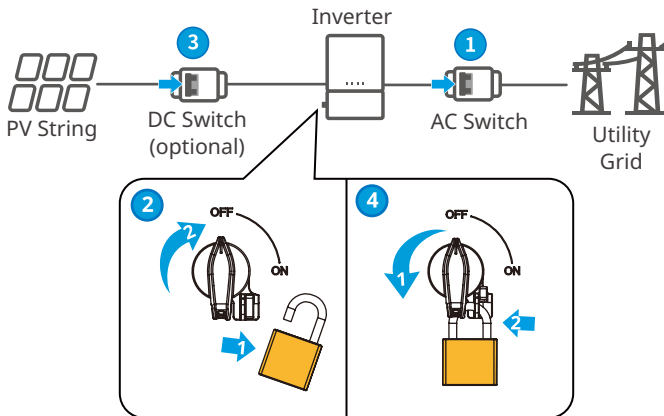

#### Power ON

Turn on 1 → 3 → 2

















#### Power OFF

Turn off 1 → 4 → 3

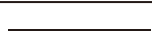

## 8 System Commissioning

### 8.1 Indicators and Buttons

Indicator	Status	Description
		ON = Equipment Power On
		OFF = Equipment Power Off
		ON = The Inverter Is Feeding Power
		OFF = The inverter is not feeding power
		Single slow flash = Self check before connecting to the grid
		Single flash = Connecting to the grid
		ON = Wireless is connected/active
		Blink 1 = Wireless system is resetting
		Blink 2 = Wireless router not connected
		Blink 4 = Wireless server problem
		Blink = RS485 is connected
		OFF = Wireless is not active
		ON = A fault has occurred
		OFF = No fault

### 8.3 Upgrading the Firmware Via USB Flash Disk

**Step 1** Contact the after-sales service to obtain the upgrade package.

**Step 2** Save the upgrade package in the USB flash drive.

**Step 3** Insert the USB flash drive into the USB port, and upgrade the software version of the inverter following the prompts.

### 8.4 Setting Inverter Parameters via SolarGo App

SolarGo app is a mobile application that communicates with the inverter via Bluetooth module, WIFI module or GPRS module. Commonly used functions are as follows:

1. Check the operating data, software version, alarms, etc.
2. Set grid parameters, communication parameters, etc.
3. Equipment maintenance.

For more details, refer to the SolarGo APP User Manual. Scan the QR code or visit [https://en.goodwe.com/Ftp/EN/Downloads/User%20Manual/GW\\_SolarGo\\_User%20Manual-EN.pdf](https://en.goodwe.com/Ftp/EN/Downloads/User%20Manual/GW_SolarGo_User%20Manual-EN.pdf) to get the user manual.



SolarGo App



SolarGo App User  
Manual

### 8.4 Monitoring via SEMS Portal

SEMS Portal is an monitoring platform used to manage organizations/users, add plants, and monitor plant status.

For more details, refer to the SEMS Portal User Manual. Scan the QR code or visit [https://en.goodwe.com/Ftp/EN/Downloads/User%20Manual/GW\\_SEMS%20Portal-User%20Manual-EN.pdf](https://en.goodwe.com/Ftp/EN/Downloads/User%20Manual/GW_SEMS%20Portal-User%20Manual-EN.pdf) to get the user manual.



SEMS Portal



SEMS Portal User  
Manual

## 9 Maintenance

### 9.1 Power Off the Inverter

#### DANGER

INSTRUCTIONS PERTAINING TO A RISK OF FIRE OR ELECTRIC SHOCK

- Power off the inverter before operations and maintenance. Otherwise, the inverter may be damaged or electric shocks may occur.
- Delayed discharge. Wait until the components are discharged after power off.

**Step 1 (Optional)** Send the Remote shutdown command to the inverter through SolarGo App.

**Step 2** Turn off the AC switch between the inverter and the utility grid.

**Step 3** Turn off the DC switch of the inverter.

### 9.2 Removing the Inverter

#### WARNING

- Make sure that the inverter is powered off.
- Wear proper PPE before any operations.

**Step 1** Disconnect all the cables, including DC cables, AC cables, communication cables, the communication module, and PE cables.

**Step 2** Grab the handles or hoist the inverter to remove the inverter from the mounting plate.

**Step 3** Remove the mounting plate.

**Step 4** Store the inverter properly. If the inverter needs to be used later, ensure that the storage conditions meet the requirements.

### 9.3 Disposing of the Inverter

If the inverter cannot work anymore, dispose of it according to the local disposal requirements for electrical equipment waste. The inverter cannot be disposed of together with household waste.

### 9.4 Troubleshooting

Perform troubleshooting according to the following methods. Contact the after-sales service if these methods do not work.

Collect the information below before contacting the after-sales service, so that the problems can be solved quickly.

1. Inverter information like serial number, software version, installation date, fault time, fault frequency, etc.
2. Installation environment, including weather conditions, whether the PV modules are sheltered or shadowed, etc. It is recommended to provide some photos and videos to assist in analyzing the problem.
3. Utility grid situation.

No.	Fault	Cause	Solutions
1	Utility Loss	1. Utility grid power fails. 2. The AC cable is disconnected, or the AC breaker is off.	1. The alarm is automatically cleared after the grid power supply is restored. 2. Check whether the AC cable is connected and the AC breaker is on.
2	Grid Overvoltage	The grid voltage exceeds the permissible range, or the duration of high voltage exceeds the requirement of HVRT.	1. If the problem occurs occasionally, the utility grid may be abnormal temporarily. The inverter will recover automatically after detecting that the utility grid is normal. 2. If the problem occurs frequently, check whether the grid voltage is within the permissible range. <ul style="list-style-type: none"> <li>• Contact the local power company if the grid voltage exceeds the permissible range.</li> <li>• Modify the overvoltage protection threshold, HVRT or disable the overvoltage protection function after obtaining the consent of the local power company if the grid frequency is within the permissible range.</li> </ul> 3. Check whether the AC breaker and the output cables are connected securely and correctly if the problem persists.
3	Grid Rapid Overvoltage	The grid voltage is abnormal or ultra-high.	1. If the problem occurs occasionally, the utility grid may be abnormal temporarily. The inverter will recover automatically after detecting that the utility grid is normal. 2. If the problem occurs frequently, check whether the grid voltage is within the allowed range. <ul style="list-style-type: none"> <li>• Contact the local power company if the grid voltage exceeds the permissible range.</li> <li>• Modify the grid overvoltage rapid protection threshold after obtaining the consent of the local power company if the grid voltage is within the permissible range.</li> </ul>

No.	Fault	Cause	Solutions
4	Grid Undervoltage	The grid voltage is lower than the permissible range, or the duration of low voltage exceeds the requirement of LVRT.	<ol style="list-style-type: none"> <li>1. If the problem occurs occasionally, the utility grid may be abnormal temporarily. The inverter will recover automatically after detecting that the utility grid is normal.</li> <li>2. If the problem occurs frequently, check whether the grid voltage is within the permissible range. <ul style="list-style-type: none"> <li>• Contact the local power company if the grid voltage exceeds the permissible range.</li> <li>• Modify the undervoltage protection threshold, LVRT or disable the undervoltage protection function after obtaining the consent of the local power company if the grid frequency is within the permissible range.</li> </ul> </li> <li>3. Check whether the AC breaker and the output cables are connected securely and correctly if the problem persists.</li> </ol>
5	Grid 10min Overvoltage	The moving average of grid voltage in 10min exceeds the range of safety requirements.	<ol style="list-style-type: none"> <li>1. If the problem occurs occasionally, the utility grid may be abnormal temporarily. The inverter will recover automatically after detecting that the utility grid is normal.</li> <li>2. If the problem occurs frequently, check whether the grid voltage is within the permissible range. <ul style="list-style-type: none"> <li>• Contact the local power company if the grid voltage exceeds the permissible range.</li> <li>• Modify the 10min overvoltage protection threshold with the consent of the local power company if the grid voltage is within the permissible range.</li> </ul> </li> </ol>

No.	Fault	Cause	Solutions
6	Grid Overfrequency	Utility grid exception. The actual grid frequency exceeds the requirement of the local grid standard.	<ol style="list-style-type: none"> <li>1. If the problem occurs occasionally, the utility grid may be abnormal temporarily. The inverter will recover automatically after detecting that the utility grid is normal.</li> <li>2. If the problem occurs frequently, check whether the grid frequency is within the permissible range.                             <ul style="list-style-type: none"> <li>• Contact the local power company if the grid frequency exceeds the permissible range.</li> <li>• Modify the overfrequency protection threshold or disable the overfrequency protection function after obtaining the consent of the local power company if the grid frequency is within the permissible range.</li> </ul> </li> </ol>
7	Grid Underfrequency	Utility grid exception. The actual grid frequency is lower than the requirement of the local grid standard.	<ol style="list-style-type: none"> <li>1. If the problem occurs occasionally, the utility grid may be abnormal temporarily. The inverter will recover automatically after detecting that the utility grid is normal.</li> <li>2. If the problem occurs frequently, check whether the grid frequency is within the permissible range.                             <ul style="list-style-type: none"> <li>• Contact the local power company if the grid frequency exceeds the permissible range.</li> <li>• Modify the underfrequency protection threshold or disable the underfrequency protection function after obtaining the consent of the local power company if the grid frequency is within the permissible range.</li> </ul> </li> </ol>
8	Grid Frequency Instability	Utility grid exception. The actual grid frequency change rate does not meet the requirement of the local grid standard.	<ol style="list-style-type: none"> <li>1. If the problem occurs occasionally, the utility grid may be abnormal temporarily. The inverter will recover automatically after detecting that the utility grid is normal.</li> <li>2. If the problem occurs frequently, check whether the grid frequency is within the permissible range.                             <ul style="list-style-type: none"> <li>• Contact the local power company if the grid frequency exceeds the permissible range.</li> <li>• Contact the dealer or the after-sales service if the grid frequency is within the permissible range.</li> </ul> </li> </ol>

No.	Fault	Cause	Solutions
9	Anti-islanding	The utility grid is disconnected. The utility grid is disconnected according to the safety regulations, but the grid voltage is maintained due to the loads.	<ol style="list-style-type: none"> <li>1. Check whether the utility grid is disconnected.</li> <li>2. Contact the dealer or the after-sales service.</li> </ol>
10	LVRT Undervoltage	Utility grid exception. The duration of the utility grid exception exceeds the set time of LVRT.	<ol style="list-style-type: none"> <li>1. If the problem occurs occasionally, the utility grid may be abnormal temporarily. The inverter will recover automatically after detecting that the utility grid is normal.</li> <li>2. If the problem occurs frequently, check whether the grid frequency is within the permissible range. If not, contact the local power company. If yes, contact the dealer or the after-sales service.</li> </ol>
11	HVRT Overvoltage	Utility grid exception. The duration of utility grid exception exceeds the set time of HVRT.	
12	Abnormal GFCI 30mA	The input insulation impedance becomes low when the inverter is working.	<ol style="list-style-type: none"> <li>1. If the problem occurs occasionally, it may be caused by a cable exception. The inverter will recover automatically after the problem is solved.</li> <li>2. Check whether the impedance between the PV string and PE is too low if the problem occurs frequently or persists.</li> </ol>
13	Abnormal GFCI 60mA		
14	Abnormal GFCI 150mA		
15	Abnormal GFCI		
16	Large DC of AC current L1	The DC component of the output current exceeds the safety range or default range.	<ol style="list-style-type: none"> <li>1. If the problem is caused by an external fault like a utility grid exception or frequency exception, the inverter will recover automatically after solving the problem.</li> <li>2. If the problem occurs frequently and the PV station cannot work properly, contact the dealer or the after-sales service.</li> </ol>
17	Large DC of AC current L2		

No.	Fault	Cause	Solutions
18	Low Insulation Res.	<ol style="list-style-type: none"> <li>The PV string is short-circuited to PE.</li> <li>The PV system is in a moist environment and the cable is not well insulated to the ground.</li> </ol>	<ol style="list-style-type: none"> <li>Check whether the resistance of the PV string to PE exceeds 50kΩ. If no, check the short circuit point.</li> <li>Check whether the PE cable is connected correctly.</li> <li>If the resistance is lower on rainy days, please reset the ISO.</li> </ol>
19	Abnormal Ground	<ol style="list-style-type: none"> <li>The PE cable of the inverter is not connected well.</li> <li>The L cable and N cable are connected reversely when output of the PV string is grounded.</li> </ol>	<ol style="list-style-type: none"> <li>Check whether the PE cable of the inverter is connected properly.</li> <li>Check whether the L cable and N cable are connected reversely if output of the PV string is grounded.</li> </ol>
20	Anti Reverse power Failure	Abnormal fluctuation of load	<ol style="list-style-type: none"> <li>If the exception is caused by an external fault, the inverter will recover automatically after solving the problem.</li> <li>If the problem occurs frequently and the PV station cannot work properly, contact the dealer or the after-sales service.</li> </ol>
21	Internal Comm Loss	<ol style="list-style-type: none"> <li>Frame format error</li> <li>Parity checking error</li> <li>Can bus offline</li> <li>Hardware CRC error</li> <li>Send (receive) control bit is receive (send).</li> <li>Transmit to the unit that is not allowed.</li> </ol>	<p>Disconnect the AC output switch and DC input switch, then connect them 5 minutes later. Contact the dealer or the after-sales service if the problem persists.</p>
22	AC HCT Check abnormal	The sampling of the AC HCT is abnormal.	<p>Disconnect the AC output switch and DC input switch, then connect them 5 minutes later. Contact the dealer or the after-sales service if the problem persists.</p>



No.	Fault	Cause	Solutions
23	GFCI HCT Check abnormal	The sampling of the GFCI HCT is abnormal.	Disconnect the AC output switch and DC input switch, then connect them 5 minutes later. Contact the dealer or the after-sales service if the problem persists.
24	Relay Check abnormal	<ol style="list-style-type: none"> <li>1. The relay is abnormal or short-circuited.</li> <li>2. The control circuit is abnormal.</li> <li>3. The AC cable connection is abnormal, like a virtual connection or short circuit.</li> </ol>	Disconnect the AC output switch and DC input switch, then connect them 5 minutes later. Contact the dealer or the after-sales service if the problem persists.
25	Internal Fan abnormal	<ol style="list-style-type: none"> <li>1. The fan power supply is abnormal.</li> <li>2. Mechanical exception.</li> <li>3. The fan is aging and damaged.</li> </ol>	Disconnect the AC output switch and DC input switch, then connect them 5 minutes later. Contact the dealer or the after-sales service if the problem persists.
26	Flash Fault	The internal Flash storage is abnormal.	Disconnect the AC output switch and DC input switch, then connect them 5 minutes later. Contact the dealer or the after-sales service if the problem persists.
27	DC Arc Fault	<ol style="list-style-type: none"> <li>1. The DC terminal is not firmly connected.</li> <li>2. The DC cable is broken.</li> </ol>	Read the Quick Installation Guide and check whether the cables are connected properly.
28	AFCI Self-test Fault	AFCI detection is abnormal.	Disconnect the AC output switch and DC input switch, then connect them 5 minutes later. Contact the dealer or the after-sales service if the problem persists.
29	Cavity Overtemperature	<ol style="list-style-type: none"> <li>1. The inverter is installed in a place with poor ventilation.</li> <li>2. The ambient temperature exceeds 60°C.</li> <li>3. A fault occurs in the internal fan of the inverter.</li> </ol>	<ol style="list-style-type: none"> <li>1. Check the ventilation and the ambient temperature at the installation point.</li> <li>2. If the ventilation is poor or the ambient temperature is too high, improve the ventilation and heat dissipation.</li> <li>3. Contact the dealer or after-sales service if both the ventilation and the ambient temperature are normal.</li> </ol>

No.	Fault	Cause	Solutions
30	BUS Overvoltage	<ol style="list-style-type: none"> <li>1. The PV voltage is too high.</li> <li>2. The sampling of the inverter BUS voltage is abnormal.</li> </ol>	Disconnect the AC output switch and DC input switch, then connect them 5 minutes later. Contact the dealer or the after-sales service if the problem persists.
31	PV Input Overvoltage	The PV array configuration is not correct. Too many PV panels are connected in series in the PV string.	Check the serial connection of the PV array. Make sure that the open circuit voltage of the PV string is not higher than the maximum operating voltage of the inverter.
32	PV Continuous Hardware Overcurrent	<ol style="list-style-type: none"> <li>1. The PV configuration is not proper.</li> <li>2. The hardware is damaged.</li> </ol>	Disconnect the AC output switch and DC input switch, then connect them 5 minutes later. Contact the dealer or the after-sales service if the problem persists.
33	PV Continuous Software Overcurrent	<ol style="list-style-type: none"> <li>1. The PV configuration is not proper.</li> <li>2. The hardware is damaged.</li> </ol>	Disconnect the AC output switch and DC input switch, then connect them 5 minutes later. Contact the dealer or the after-sales service if the problem persists.
34	String1 PV String Reversed	The PV string is connected reversely.	Check whether the PV1 and PV2 strings are connected reversely.
35	String2 PV String Reversed		

## 9.5 Routine Maintenance

 **WARNING**

- Make sure that the inverter is powered off.
- Wear proper PPE before any operations.

Maintaining Item	Maintaining Method	Maintaining Period
System Clean	Check the heat sink, air intake, and air outlet for foreign matter or dust.	Once 6-12 months
DC Switch	Turn the DC switch on and off ten consecutive times to make sure that it is working properly.	Once a year
Electrical Connection	Check whether the cables are securely connected. Check whether the cables are broken or whether there is any exposed copper core.	Once 6-12 months
Sealing	Check whether all the terminals and ports are properly sealed. Reseal the cable hole if it is not sealed or too big.	Once a year

## 10 Technical Parameters

Technical Data	GW5000-MS-US30	GW6000-MS-US30	GW7600-MS-US30
<b>Input</b>			
Max.Input Power (W)	8,000	9,600	12,160
Max.Input Voltage (V)	600	600	600
MPPT Operating Voltage Range (V)	65~550	65~550	65~550
MPPT Voltage Range at Nominal Power (V) (at 240V)	165-500	198-500	250-500
MPPT Voltage Range at Nominal Power (V) (at 208V)	143-500	171-500	217-500
Start-up Voltage (V)	80	80	80
Nominal Input Voltage (V) (at 240V)	380	380	380
Nominal Input Voltage (V) (at 208V)	330	330	330
Max. Input Current per MPPT (A)	16	16	16
Max. Short Circuit Current per MPPT (A)	23.4	23.4	23.4
Max.Backfeed Current to The Array (A)	0	0	0
Number of MPP trackers	2	2	2
Number of Strings per MPPT	1	1	1
<b>Output</b>			
Nominal Output Power (W) (at 240V)	5,000	6,000	7,600
Nominal Output Power (W) (at 208V)	4,333	5,200	6,580
Nominal Output Apparent Power (VA)(at 240V)	5,000	6,000	7,600
Nominal Output Apparent Power (VA)(at 208V)	4,333	5,200	6,580
Max. AC Active Power (W)(at 240V)	5,000	6,000	7,600
Max. AC Active Power (W)(at 208V)	4,333	5,200	6,580
Max. AC Apparent Power (VA) (at 240V)	5,000	6,000	7,600
Max. AC Apparent Power (VA) (at 208V)	4,333	5,200	6,580
Nominal Output Voltage (V)	240/208	240/208	240/208
Output Voltage Range (V)(at 240V) (according to local standard)	211~264	211~264	211~264
Output Voltage Range (V)(at 208V) (according to local standard)	183~229	183~229	183~229

Nominal AC Grid Frequency (Hz)	60	60	60
AC Grid Frequency Range (Hz)	58~62	58~62	58~62
Max. Output Current (A)	20.8	25.0	31.7
Max. Output Fault Current (Peak and Duration) (A/ms)(at 20us)	68	68	68
Inrush Current (Peak and Duration) (A/us)(at 20us)	58	58	58
Nominal Output Current (A)	20.8	25.0	31.7
Power Factor	~1 (Adjustable from 0.8 leading to 0.8 lagging)		
Max. Total Harmonic Distortion	<3%		
Maximum Output Overcurrent Protection (A)	68	68	68
<b>Efficiency</b>			
Max. Efficiency	97.5%	97.5%	97.5%
CEC Efficiency(at 240V)	96.5%	96.5%	96.5%
CEC Efficiency(at 208V)	96.0%	96.0%	96.5%
<b>Protection</b>			
PV String Current Monitoring	Integrated		
PV Insulation Resistance Detection	Integrated		
Residual Current Monitoring	Integrated		
PV Reverse Polarity Protection	Integrated		
Anti-islanding Protection	Integrated		
AC Overcurrent Protection	Integrated		
AC Short Circuit Protection	Integrated		
AC Overvoltage Protection	Integrated		
DC Switch	Integrated		
DC Surge Protection	Type III (Type II Optional)		
AC Surge Protection	Type III (Type II Optional)		
AFCI	Integrated		
Rapid Shutdown	Integrated		
Power Supply at Night	Integrated		
<b>General Data</b>			
Operating Temperature Range (°F)	-13~+140(-25°C~60°C)		
Derating temperature (°F)	113 (45°C)		
Storage Temperature Range (°F)	-40~ +158(-40~+70 °C)		
Relative Humidity	0~95%		
Max. Operating Altitude (ft)	9842 (3000m)		
Cooling Method	Natural Convection		

Display	LED, WLAN+APP
Communication	RS485,WiFi or Bluetooth or 4G or LAN(Optional)
Communication Protocols	Modbus-RTU(SunSpec Compliant)
Weight (Ib)	51.8 (23.0kg)
Dimension (W×H×D in)	19.2×26.4×7.8(487×670×199mm)
Noise Emission (dB)	<25
Topology	Non-isolated
Self-consumption at Night (W)	<5
Ingress Protection Rating	Type 4X (IP66)
Anti-corrosion Class	C4
Environmental Category	4K4H
Pollution Degree	III
Overvoltage Category	DC II / AC IV
Protective Class	I
The Decisive Voltage Class (DVC)	PV:C AC:C Com:A
Active Anti-islanding Method	AFDPF + AQDPF *1
Country of Manufacture(Only for Australia)	China

Technical Data	GW7700-MS-US30	GW9600-MS-US30	GW11K4-MS-US30
<b>Input</b>			
Max.Input Power (W)	12,320	15,360	18,240
Max.Input Voltage (V)	600	600	600
MPPT Operating Voltage Range (V)	65-550	65-550	65-550
MPPT Voltage Range at Nominal Power (V) (at 240V)	170-500	210-500	250-500
MPPT Voltage Range at Nominal Power (V) (at 208V)	150-500	182-500	217-500
Start-up Voltage (V)	80	80	80
Nominal Input Voltage (V) (at 240V)	380	380	380
Nominal Input Voltage (V) (at 208V)	330	330	330
Max. Input Current per MPPT (A)	16	16	16
Max. Short Circuit Current per MPPT (A)	23.4	23.4	23.4
Max.Backfeed Current to The Array (A)	0	0	0
Number of MPP trackers	3	3	3
Number of Strings per MPPT	1	1	1

Output			
Nominal Output Power (W) (at 240V)	7,680	9,600	11,400
Nominal Output Power (W) (at 208V)	6,650	8,320	9,880
Nominal Output Apparent Power (VA)(at 240V)	7,680	9,600	11,400
Nominal Output Apparent Power (VA)(at 208V)	6,650	8,320	9,880
Max. AC Active Power (W)(at 240V)	7,680	9,600	11,400
Max. AC Active Power (W)(at 208V)	6,650	8,320	9,880
Max. AC Apparent Power (VA) (at 240V)	7,680	9,600	11,400
Max. AC Apparent Power (VA) (at 208V)	6,650	8,320	9,880
Nominal Output Voltage (V)	240/208	240/208	240/208
Output Voltage Range (V)(at 240V) (according to local standard)	211~264	211~264	211~264
Output Voltage Range (V)(at 208V) (according to local standard)	183~229	183~229	183~229
Nominal AC Grid Frequency (Hz)	60	60	60
AC Grid Frequency Range (Hz)	58~62	58~62	58~62
Max. Output Current (A)	32.0	40.0	47.5
Max. Output Fault Current (Peak and Duration) (A/ms)(at 20us)	68	101	101
Inrush Current (Peak and Duration) (A/us)(at 20us)	58	58	58
Nominal Output Current (A)	32.0	40.0	47.5
Power Factor	~1 (Adjustable from 0.8 leading to 0.8 lagging)		
Max. Total Harmonic Distortion	<3%		
Maximum Output Overcurrent Protection (A)	101	101	101
Efficiency			
Max. Efficiency	97.5%	97.8%	97.8%
CEC Efficiency(at 240V)	96.5%	97.0%	97.0%
CEC Efficiency(at 208V)	96.5%	96.5%	96.5%
Protection			
PV String Current Monitoring	Integrated		
PV Insulation Resistance Detection	Integrated		
Residual Current Monitoring	Integrated		
PV Reverse Polarity Protection	Integrated		

Anti-islanding Protection	Integrated
AC Overcurrent Protection	Integrated
AC Short Circuit Protection	Integrated
AC Overvoltage Protection	Integrated
DC Switch	Integrated
DC Surge Protection	Type III (Type II Optional)
AC Surge Protection	Type III (Type II Optional)
AFCI	Integrated
Rapid Shutdown	Integrated
Power Supply at Night	Integrated
<b>General Data</b>	
Operating Temperature Range (°F)	-13~+140(-25°C~60°C)
Derating temperature (°F)	113 (45°C)
Storage Temperature Range (°F)	-40~ +158(-40~+70 °C)
Relative Humidity	0~95%
Max. Operating Altitude (ft)	9842 (3000m)
Cooling Method	Natural Convection
Display	LED, WLAN+APP
Communication	RS485,WiFi or Bluetooth or 4G or LAN(Optional)
Communication Protocols	Modbus-RTU(SunSpec Compliant)
Weight (lb)	55.1 (25kg)
Dimension (W×H×D in)	19.2×26.4×7.8(487×670×199mm)
Noise Emission (dB)	<35
Topology	Non-isolated
Self-consumption at Night (W)	<5
Ingress Protection Rating	Type 4X (IP66)
Anti-corrosion Class	C4
Environmental Category	4K4H
Pollution Degree	III
Overvoltage Category	DC II / AC IV
Protective Class	I
The Decisive Voltage Class (DVC)	PV:C AC:C Com:A
Active Anti-islanding Method	AFDPF + AQDPF *1
Country of Manufacture(Only for Australia)	China

\*1. AFDPF: Active Frequency Drift with Positive Feedback, AQDPF: Active Q Drift with Positive Feedback



## 11 Appendix

### 11.1 Precision of inverter parameters

For parameter, which used in grid support and protection function, adjustable requirement of CA Rule 21, HECO 14H and IEEE1547, the relevant explanations and setting methods can obtain by reading, <Parameter Adjustable Method Of Grid Support Utility Interactive Inverter>, the document can be obtained by contacting the after-sales.

Time frame	Steady-state measurements			Transient measurements		
	Minimum measurement accuracy	Measurement window	Range	Minimum measurement accuracy	Measurement window	Range
Voltage, RMS	( $\pm 1\% V_{nom}$ )	10 cycles	0.5 p.u. to 1.2 p.u.	( $\pm 2\% V_{nom}$ )	5 cycles	0.5 p.u. to 1.2 p.u.
Frequency <sup>b</sup>	10 mHz	60 cycles	50 Hz to 66 Hz	100 mHz	5 cycles	50 Hz to 66 Hz
Active Power	( $\pm 5\% S_{rated}$ )	10 cycles	0.2 p.u. < P < 1.0 p.u.	Not required	N/A	N/A
Reactive Power	( $\pm 5\% S_{rated}$ )	10 cycles	0.2 p.u. < Q < 1.0 p.u.	Not required	N/A	N/A
Time	1% of measured duration	N/A	5s to 600s	2 cycles	N/A	100 ms < 5 s



Official Website

**GoodWe Technologies Co.,Ltd.**

---

 No. 90 Zijin Rd., New District, Suzhou, 215011, China

 [www.goodwe.com](http://www.goodwe.com)

 [service@goodwe.com](mailto:service@goodwe.com)



Contact Information